



USER GUIDE

**BELLING VISION 60cm ELECTRIC INDUCTION SINGLE OVEN
MODELS**

Table Of Contents

INTRODUCTION	3
MODELS COVERED BY THIS DOCUMENT	3
COUNTRIES OF DESTINATION:	3
CONTACT INFORMATION:	3
EUROPEAN DIRECTIVES	4
DISPOSAL OF PACKAGING MATERIAL	4
SAFETY & WARNING INFORMATION	5
ELECTROMAGNETIC INTERFERENCE	12
GETTING TO KNOW YOUR NEW APPLIANCE	13
APPLIANCE OVERVIEW	13
OVERVIEW OF CONTROL PANEL	14
OVERVIEW OF INDUCTION HOB	14
ABOUT THE INDUCTION HOB	15
INDUCTION SYMBOLS AND CODES	18
OVERVIEW OF OVEN FURNITURE	20
OVEN OVERVIEW	23
USING THE MAIN OVEN	27
USING THE GRILL	29
GRILL PAN AND TRIVET	30
USING THE PROGRAMMABLE TIMER	31
CLEANING YOUR APPLIANCE	34
CLEANING AND CARE GUIDANCE	35
APPLIANCE MAINTENANCE	40
CHANGING THE LIGHTBULB	40
OVEN SHELVES	40
REMOVING AND REPLACING SHELF GUIDES	41
REMOVING AND RE-FITTING CONTROL KNOBS, SPRINGS AND BEZELS	42
REMOVING THE INNER GLASS PANEL	43
DOOR REMOVAL	44
FAQ's	47
KEY PARTS AND OPTIONAL ACCESSORIES	53
LOCATING THE MODEL AND SERIAL NUMBERS	55
TECHNICAL DATA	56
ENERGY DATA TABLE	57
ENERGY SAVING TIPS FOR HOBS	58
ENERGY SAVING TIPS FOR OVENS	58
SERVICE CONTACT DETAILS	59

INTRODUCTION

Congratulations and thank you for purchasing your new Stoves range cooker. We hope you will enjoy many years of excellent cooking performance and service.

This user guide is designed to help you to care for and get the best out of your new product.

Please read it carefully before you start using your appliance, as we have endeavoured to answer as many questions as possible and provide you with as much support as we can.

General information, spares and service information is available from our website.

If you should find something missing from your product or have any questions that are not covered in this user guide, please contact us (see contact information on the back cover).

FR - France	
NL - Netherlands	
PL - Poland	
SE - Sweden	
AU - Australia	
NZ - New Zealand	

CONTACT INFORMATION:

Customer Care Helpline:

0344 815 3746

Alternatively, use the contact form on our website

www.belling.co.uk

Details about warranty registration and spares & service information are also available on our website.

MODELS COVERED BY THIS DOCUMENT

Models Covered By This Document:

Model Number:	Model Description:
444412053	BEL FSA VISION SGL 60Ei BLK
444412054	BEL FSA VISION SGL 60Ei BSS

COUNTRIES OF DESTINATION:

GB- United Kingdom	✓
IE - Ireland	✓
BE - Belgium	
DE - Germany	

Calls are charged at the basic rate, please check with your telephone service provider for exact charges.

Your new appliance comes with our FREE 2 year warranty (UK only), protecting you against electrical and mechanical breakdown.



To register your new appliance for its warranty (UK only) please visit our website www.belling.co.uk. For full terms & conditions of the manufacturer's guarantee, please refer to the website above.

In addition, you may wish to purchase an extended warranty. Details of how to do this are also on our website www.belling.co.uk.

Our policy is one of constant development and improvement, therefore we cannot guarantee the strict accuracy of all of our illustrations and specifications. Changes may have been made subsequent to publishing.

Glen Dimplex Home Appliances, Element,
Temple Court, Risley, Warrington, WA3 6GD.

EUROPEAN DIRECTIVES

This appliance is produced in accordance with all applicable local and international standards and regulations.

As a producer and a supplier of cooking appliances we are committed to the protection of the environment and are in compliance with the WEEE directive.

All our electric products are labelled accordingly with the crossed out wheeled bin symbol. This indicates, for disposal purposes at the end of their working life, that these products must be taken to a recognized collection point, such as local authority sites/ local recycling centres.



DISPOSAL OF PACKAGING MATERIAL

Some of the materials used to package this appliance can be recycled. Please dispose of the packaging materials in the appropriate containers at your local waste disposal facility.

By ensuring that this product is disposed of correctly, you will help prevent potential negative consequences for the environment and human health, which could otherwise be caused by inappropriate waste handling of this product.

For more detailed information about recycling of this product, please contact your local authority, household waste disposal service, or the retailer from whom you purchased this appliance.

This appliance complies with European Community Directives (CE) for household and similar electrical appliances and Gas appliances where applicable.

This appliance conforms to European Directive regarding Eco design requirements for energy-related products. Our policy is one of constant development and improvement, therefore we cannot guarantee the strict accuracy of all of our illustrations and specifications - changes may have been made subsequent to publishing.

DISPOSAL OF PACKAGING MATERIAL

SAFETY & WARNING INFORMATION

Please read the following information carefully:

WARNINGS



Warning

We strongly recommend that this appliance is connected by a competent person who is a member of a 'Competent Person Scheme', who will comply with the required regulations.

Any servicing, maintenance or repair work on the appliance must only be carried out by authorised personnel.

Installation, maintenance and repair work that is carried out by unauthorised persons could be dangerous and could invalidate the manufacturer's warranty.



Warning

This appliance can be used by children aged from 8 years and above and persons with reduced physical, sensory or mental capabilities or lack of experience and knowledge if they have been given supervision or instruction concerning use of the appliance in a safe way and understand the hazards involved.

Children shall not play with the appliance.

Cleaning and user maintenance shall not be made by children without supervision.

Young children should be supervised to ensure they do not play with this appliance.

Do not store items of interest to children in cabinets above the appliance. Children climbing on the appliance could be seriously injured.



Warning

If the hotplate surface is cracked, switch off the appliance and do not use it to avoid the possibility of electric shock.

**Warning**

During use the appliance becomes hot. Care should be taken to avoid touching heating elements inside the oven.

**Warning**

Metallic objects such as knives, forks, spoons and lids should not be placed on the hob surface since they can get hot.

Any spillage should be removed from the lid before opening and the hob surface should be allowed to cool before closing the lid (if fitted).

**Warning**

The appliance and its accessible parts become hot during use.

Care should be taken to avoid touching heating elements, and hot external and internal surfaces, including doors.

Use oven gloves.

Children less than 8 years of age shall be kept away unless continuously supervised.

**Warning**

Ensure that the appliance is switched off before replacing the lamp to avoid the possibility of electric shock.

**Warning**

The cooker must be switched off before removing the guard and, after cleaning, the guard must be replaced in accordance with the instructions.

**Warning**

Unattended cooking on a hob with fat or oil can be dangerous and may result in fire. Risk of burns and scalds.

NEVER try to extinguish a fire with water, but switch off the appliance and then cover the flames e.g. with a lid or a fire blanket.

**Warning**

A steam cleaner is not to be used on this appliance.

**Warning**

Danger of fire: do not store items on the cooking surfaces or in the oven cavities.

**Warning**

Use only hob guards designed by the manufacturer of the cooking appliance or indicated by the manufacturer of the appliance in the instructions for use as suitable or hob guards incorporated in the appliance. The use of inappropriate guards can cause accidents.

**Warning**

Do not store or use flammable liquids or items in the vicinity of this appliance.

Do not allow curtains, paper or other flammable items to come into contact with the cooker.

Do not spray aerosols in the vicinity of the appliance while it is in operation.

**Warning**

Never place food, or dishes on the base of the main oven, the element is here, and it will cause overheating.

**Warning**

Do not modify this appliance.

**Warning**

Do not place articles on or against the appliance.

**Warning**

Do not operate the appliance without the glass door panels correctly fitted.

**Warning**

The appliance must never be disconnected from the mains supply during use, as this will seriously affect the safety and performance, particularly in relation to surface temperatures becoming hot and gas operated parts not working efficiently.

The cooling fan (if fitted) is designed to run on after the control knob has been switched off.

**Warning**

Accessible parts may become hot when the grill is in use. Children should be kept away.

**Warning**

If a lid is fitted to your appliance any spillage should be removed from the lid before opening and the hob surface should be allowed to cool before closing the lid.

**Warning**

This appliance must be earthed.

**Warning**

The grill **MUST** be used with the door **CLOSED**.

**Warning**

This appliance must not be used as a space heater.

**Warning**

Never use cooking vessels on the hob that overlap its edges.

Saucepan handles may become hot during use.

Keep pan handles out of the reach of children.

**Warning**

If the electrical connection cable becomes damaged, it must be replaced by a suitably-qualified person.

The cable must not be replaced by an unauthorised person.

CAUTIONS

**Caution**

In order to avoid a hazard due to inadvertent resetting of the thermal cut-out, this appliance must not be supplied through an external switching device, such as an external timer, or connected to a circuit that is regularly switched on and off by the utility.



Caution

Do not use harsh abrasive cleaners or sharp metal scrapers to clean the oven door glass / the hob surface / the glass of hinged lids of the hob (as appropriate), since they can scratch the surface, which may result in shattering of the glass.

Always ensure that the appliance is switched off before cleaning or carrying out user maintenance.

Do not clean the appliance with a steam cleaner.

Always clean up food spillages immediately, after switching the appliance off, taking care to avoid burning yourself.

Do not use scourers, sharp metal scrapers or any abrasive or corrosive cleaning agents - risk of damage and glass breakage.

Do not remove the data badge labels or clean them with corrosive cleaners.

Do not allow pans to boil dry - risk of damage to ceramic glass surface.

Do not use pans with jagged edges or drag pans across the ceramic glass surface as this can scratch the glass and lead to breakage.

Do not attempt to cook on a broken ceramic glass hotplate -risk of electric shock. Switch the appliance off immediately at the mains power supply

and call the service department.

Do not operate hob zones without a pan in place.

Do not place or drop heavy objects onto the ceramic hob surface.

Do not stand on the hob surface.

Do not allow any part of your body, hair, clothing, etc. to come into contact with the ceramic glass surface until it has cooled.



Caution

Only use the temperature probe recommended for this oven.



Caution

After use, switch off the hob zone by its control knob or touch control, and do not rely on the pan detector on induction hobs.

After use, ensure that all touch controls are switched off and that all control knobs are in the off position.



Caution

This appliance is not intended to be operated by means of an external timer or separate remote control system.

**Caution**

The cooking process must be supervised. A short-term cooking process has to be supervised continuously.

**Caution**

Accessible parts may be hot when the grill and/or the oven are in use. Young children shall be kept away.

**Caution**

Our policy is one of constant development and improvement, therefore we cannot guarantee the strict accuracy of all of our illustrations and specifications. Changes may have been made subsequent to publishing.

**Caution**

Make sure that you have removed all packaging and wrapping from the outside and inside of the appliance before it is used.

Some of the items inside this appliance may have additional wrapping.

It is advised that you turn the ovens and/or grill on for a short while. This will burn off any residues left from manufacturing. There may be a smell which accompanies this process - but this is nothing to worry about and is harmless.

It is recommended that you wash the oven shelves, grill pan, and grill pan trivet before their first use in hot soapy water. This will remove the protective oil coating used during storage.

**Caution**

When using the grill, the oven door must be kept **CLOSED**.

**Caution**

This appliance is designed for cooking purposes only. It must not be used for other purposes, for example room heating.

**Caution**

When opening oven doors, grip the handle in the centre and hold it from underneath.

**Caution**

Do not cover the appliance.

**Caution**

Take care if moving the appliance, panel edges could be sharp. Failure to use caution could result in injury or cuts. Do not attempt to lift or move the appliance by pulling on the door handles.

**Caution**

If you will not be using the appliance for some time, switch off the power supply at the isolator switch on the wall.

OTHER SAFETY ADVICE

DO

- Always take care when removing food from the oven as the area around the cavity may be hot.
- Always use oven gloves when handling any cookware that has been in the oven as it will be hot.
- Always make sure that the oven shelves are resting in the correct position between two runners.
- Always use the Minute Minder (if fitted) if you are leaving the oven unattended - this reduces the risk of food burning.

DO NOT

- Never place dishes or other items on the door while it is open. Do not apply downward pressure to open oven doors. Do not allow children to climb onto open oven doors. Do not slam the oven doors shut. When shutting oven doors, ensure there is nothing obstructing them from closing. Risk of breakage.
- Never wrap foil around the oven shelves or allow foil to block the flue. Do not line the oven cavities or grill pan with aluminium foil - risk of fire. Do not use liners on the oven floors - risk of build-up of trapped heat which can cause permanent damage to the oven enamel.
- Never drape tea towels, dishcloths or clothes, etc. near the oven or from the door handles while it is on; this will cause a fire hazard.
- Never pull heavy items, such as turkeys or large joints of meat, out from the oven on the shelf, as they may overbalance and fall.
- Never use this appliance to heat anything other than food items and do not use it for heating the room.

FIRE SAFETY ADVICE

Most kitchen fires occur when people are distracted or leave things unattended. Don't let yourself be distracted while cooking. If you're called away from the cooker, either take pans off the heat, or switch off your hob.

If you do have a fire in the kitchen, don't take any risks - get everyone out of your home and call the Fire Brigade.

If a pan catches fire:

- Do not move it - it is likely to be extremely hot.
- Turn off the heat if it's safe to do so - but never lean over a pan to reach the controls.
- If you have a fire blanket, put it over the pan. If you have put the fire out, leave the pan to cool completely.

Deep-fat frying presents more dangers in your kitchen.

- Never fill a chip pan (or other deep fat fryer) more than one-third full of oil.

- **Do not use a fire extinguisher on a pan of oil - the force of the extinguisher can spread the fire and create a fireball.**

If you have an electrical fire in the kitchen:

- **Pull the plug out, or switch off the power at the fuse box - this may be enough to stop the fire immediately.**
- **Smother the fire with a fire blanket, or use a dry powder or carbon dioxide extinguisher.**
- **Remember: never use water on an electrical or cooking oil fire.**

ELECTROMAGNETIC INTERFERENCE

The functions of the hob comply with the applicable standard on electromagnetic interference.

Your induction cooking hob thus complies fully with the statutory requirements (Directive 2014/30/EU). It is designed to not interfere with the functioning of other electrical equipment as long as these also comply with the same regulations.

Your induction hob generates magnetic fields in its immediate vicinity.

So that there is no interference between your cooking hob and a pacemaker, the pacemaker must be designed in compliance with the appropriate regulations.

In this respect we can only guarantee the compliance of our own product. You can ask the pacemaker manufacturer or your doctor about the compliance or any incompatibilities of your pacemaker.

GETTING TO KNOW YOUR NEW APPLIANCE

The layout of your appliance may differ from the drawings shown in this guide depending on the model.

APPLIANCE OVERVIEW

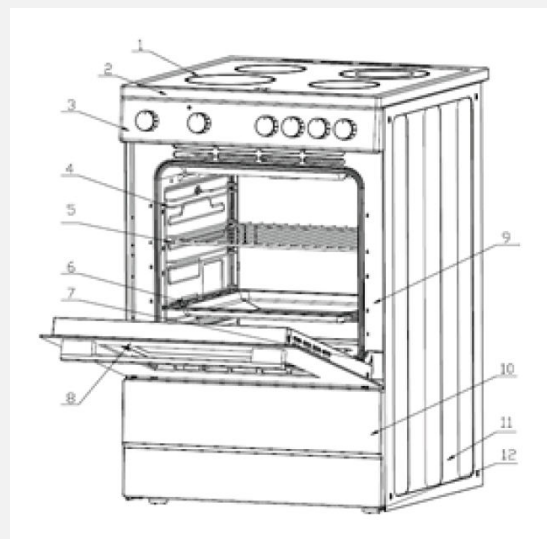

Key	Description
1	Induction hob cooking zones
2	Induction hob hotplate
3	Control panel
4	Oven shelf guides and stay-clean catalytic liners on sides
5	Oven shelf
6	Grill pan - can also be used as a baking tray or roasting tin
7	Door handle
8	Oven door
9	Oven front frame with door seal
10	Decorative front panel
11	Side panel
12	Height-adjustable feet

OVERVIEW OF CONTROL PANEL

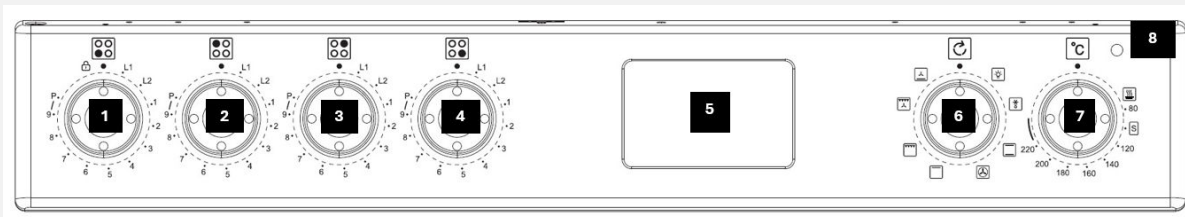

Key	Description
1	Induction hob control for the front-left zone - also includes the child-lock function
2	Induction hob control for the back-left zone
3	Induction hob control for the back-right zone
4	Induction hob control for the front-right zone
5	Programmable timer and minute minder - controls the oven
6	Oven function selector control
7	Oven temperature control
8	Oven heating indicator light

OVERVIEW OF INDUCTION HOB

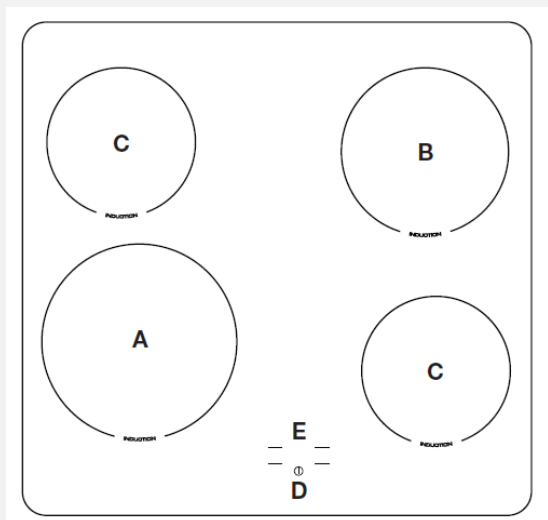

Key	Description	Location	Zone diameter	Power	Minimum recommended pan diameter size
A	Large induction zone	Front-left	210mm	2300 watts - boost to 3000 watts	160mm
B	Medium induction zone	Back-right	180mm	1800 watts - boost to 2100 watts	140mm
C	Small induction zones	Back-left and front-right	160mm	1200 watts - boost to 1500 watts	120mm
D	On/off power key - touch control	Front			
E	Hob zone power level indicators	Front			

Pans must have smooth, flat, magnetic bases. The hob may not detect pans with a smaller base diameter than 120mm. Generally, induction hobs cannot detect pans with a base diameter of 100mm or less.

ABOUT THE INDUCTION HOB

TURNING THE INDUCTION HOB ON AND OFF

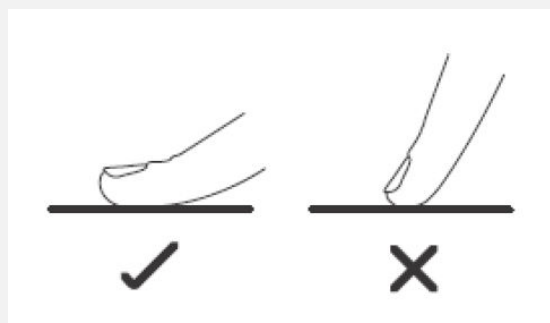

Tip

When using the touch control power key, please use the flat of your finger for best results, not the tip. You don't need to apply any pressure.

Please ensure that the touch control is clean, dry and not covered by any objects, such as cooking utensils or cloths. Even a thin film of water, grease, dust or fingerprints could make the touch control difficult to operate.

- The induction hob is switched on by touching and holding the power key ① until the hob display lights up, showing dashes ('-').
- Once powered up you can then use the rotary controls to operate the cooking zones.
- The whole hob can be switched off by touching and holding the power key ① until the display goes dark.

SELECTING A POWER LEVEL ON A COOKING ZONE

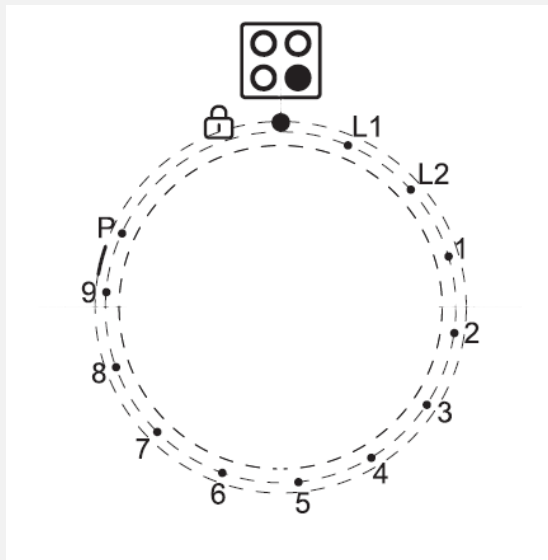

- Turn the control knob for the relevant cooking zone clockwise to the desired power level (with L1 being the lowest power level and 9 being the highest power level).
- The chosen power level is shown in the display.
- A beep sounds each time the control knob is turned to a different power level.
- The power level can be changed at any time by turning the control knob.

SUGGESTED HEAT SETTINGS

Heat Setting	Suggested uses
L1, L2	Melting chocolate, butter and foods which can burn quickly Keeping cooked food warm prior to serving Gentle simmering
1, 2	Delicate warming for small amounts of food Slow warming
3, 4	Reheating and rapid simmering Cooking rice
5, 6	Making pancakes
7, 8	Sautéing Cooking food
9	Stir-frying Searing Bringing soup to the boil Boiling water
P - power boost	Bringing larger amounts of water to the boil more quickly. Do not use for heating oil.

SWITCHING A COOKING ZONE OFF

Turn the relevant control knob anti-clockwise to the off position to turn the cooking zone off.



Note

- Always turn the hob control knobs to the off position before switching the hob off with the power key ①.
- If a hob zone control knob is accidentally left in a power level position when the hob is switched off by the power key, when the hob is later switched back on the zone will stay powered off and will not respond to the control knob being turned to different power levels.
- If this happens, turn the knob anti-clockwise to the off position, and then turn it back clockwise to the required power level.
- The zone will now respond to the control knob as usual.

USING THE POWER BOOST FUNCTION

The power boost is a function that temporarily boosts the power to a cooking zone.

- Rotate the relevant control knob to the right (clockwise) as far as it will go, past the level 9 position to the 'P' position.
- Release the control knob and it will rest on the power level 9 position.
- The display shows the 'P' symbol and the power boost will operate for approximately 5 minutes, before returning to power level 9.
- Alternatively, power boost can be cancelled at any time by selecting a different power level, or by turning the control knob to the 'P' position again.



Note

After approximately 5 minutes the power boost is automatically switched off and the zone returns to power level 9. Please note, if you adjust the power level down from power boost, the zone display will change from 'P' to '8', rather than from 'P' to '9' because the control knob was already in the power level 9 position.

Power boost works by temporarily 'borrowing' extra power from an adjacent zone. Therefore it is not possible to boost all 4 cooking zones at the same time.

When using power boost on one zone, the electronics may need to automatically reduce the power of the adjacent zone on the same side of the hob. This is normal and is designed to prevent the appliance drawing too much power.

Do not hold the the hob zone control knob in the 'P' position for more than a couple of seconds. If you were to hold the control knob in the 'P' position for too long, the beeping would sound to remind you to release the control knob.

ACTIVATING AND DEACTIVATING THE HOB CHILD-LOCK

- First ensure that no hob zones are currently in use. All of the hob control knobs must be in the off position.



- To prevent accidental operation of the cooking zones, turn the front-left cooking zone control knob to the left (anti-clockwise) and hold it at the child lock symbol  for about 3 seconds.
- A beep sounds. Release the knob and it returns to rest on the off position. The lock will activate and 'LO' will appear on the display.
- While the child lock is active, turning the hob zone control knobs has no effect.
- Please note, the 'LO' message can appear in the hob display even if the hob is powered off, as long as the cooker is switched on at the wall.
- To deactivate the child lock repeat the above operation, turn the front-left cooking

zone control knob to the left (anti-clockwise) and hold it at the child lock symbol  for about 3 seconds.

- A beep sounds, the lock will deactivate and 'LO' will disappear from the display.
- The hob will become operational again and can be powered on and used normally.

INDUCTION SYMBOLS AND CODES

The hob display can show information codes, and codes to alert you to any issues which may need to be resolved.

Symbol / Code	Meaning	Description
-	Hob is powered on but not in use.	The dash symbol means that the hob has been powered up by touching the on/off power key but no power levels have been chosen for the cooking zones. Choose a power level by turning the relevant control knob. If no power levels are chosen within about 1 minute, the hob will switch off again and return to standby mode.
	Pan missing, or unsuitable pan.	If the electronics cannot detect the pan, because it is too small or does not have a magnetic base, then the hob display will show the missing or unsuitable pan symbol.
	Residual heat indicator.	When the cooking zone or hob is switched off after use, if the glass surface is still hot, the residual heat indicator will be displayed. The residual heat symbol will automatically go out when the glass surface temperature cools (to below approximately 45°C). The cooling fan runs for a while after the hob is switched off to help cool the hob electronics.
	Power boost.	Power boost is active.
ER03	Obstruction.	Something is covering the hob display area, such as a pan, utensil or cloth, or even just water, grease or finger prints . Remove the item and clean the area before using the hob again.

Symbol / Code	Meaning	Description
E6 or E9	Over-heat indicator.	The hotplate may have over-heated, possibly because an empty pan has been heated for too long or a pan has boiled dry. Remove the pans and allow the hob to cool down for about 30 minutes before trying to use it again.
E2 or E3	Possible issue with electricity supply.	The electrical voltage supplying the cooker may be too high or too low. Switch the cooker off at the wall and contact your local electricity board for assistance.
L1 or L2	Low temperature setting.	The cooking zone has been set to a low temperature setting. You can turn the control knob to a different setting to choose a different power level.
LO	Child lock.	The child lock has been activated.

For other codes, please switch the appliance off at the wall for a few minutes to let the electronics reset. If the code reappears when the power is restored, please contact our customer support team using the details on the back cover.



AUTOMATIC SHUTDOWN

Automatic shutdown is an additional safety feature which will switch the hob cooking zones off should you ever forget to turn a zone off. The maximum operating times for each power level are shown below.

Power Level	Maximum Operating Time
L1	2 hours
L2	2 hours
1	8 hours

Power Level	Maximum Operating Time
2	8 hours
3	8 hours
4	4 hours
5	4 hours
6	4 hours
7	2 hours
8	2 hours
9	2 hours
P - Power Boost	5 minutes (plus 2 hours at power level 9)

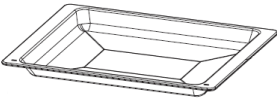
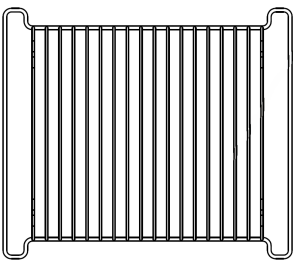
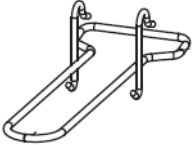
OVERVIEW OF OVEN FURNITURE

Item	Quantity supplied with cooker	Notes
 <p>Full-width deep grill-pan</p>	1	<p>Can also be used as a baking tray or roasting tin.</p> <p>Used in the oven.</p>
 <p>Grill-pan trivet</p>	1	<p>Place inside the grill-pan to support the food being grilled.</p> <p>The useable grilling area is approximately 300mm wide by 280mm deep.</p>
 <p>Grill-pan handle</p>	1	<p>Hooks over the front of the grill-pan to make it easier to insert and withdraw the grill-pan.</p> <div data-bbox="762 1301 1385 1554" style="background-color: #e0e0e0; padding: 10px; margin-top: 10px;"> <p> Warning Do not use the handle to carry the grill-pan - danger of scalding or injury.</p> </div>

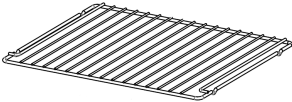
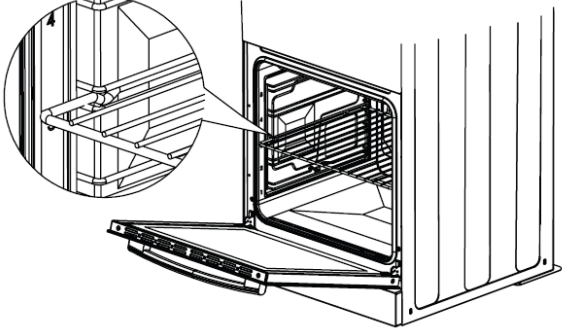
Item	Quantity supplied with cooker	Notes
 <p data-bbox="209 533 280 562">Shelf</p>	<p data-bbox="576 383 596 412">2</p>	<p data-bbox="762 383 1206 412">The shelves are used in the oven.</p>  <p data-bbox="762 842 1342 913">Insert the shelf with the anti-tip notches at the back and facing downwards.</p> <div data-bbox="762 981 1385 1570" style="background-color: #f0f0f0; padding: 10px;"> <p data-bbox="802 1032 871 1088"></p> <p data-bbox="903 1032 1046 1066">Warning</p> <p data-bbox="916 1077 1331 1261">Insert the shelf between the two wires of the shelf guide position, not on top of the upper wire - danger of scalding or injury.</p> <p data-bbox="916 1301 1342 1518">Do not attempt to place a shelf on top of the shelf guides as the shelf will not be held in a stable position and could tip out - danger of scalding or injury.</p> </div> <p data-bbox="762 1641 1382 1749">When removing a shelf for cleaning, wait for the shelf to cool, then pull it outwards and lift it upwards to remove it completely.</p> <p data-bbox="762 1787 1299 1852">The useable shelf area is approximately 390mm wide by 360mm deep.</p>

Item	Quantity supplied with cooker	Notes
		The maximum recommended size of baking tray to use is approximately 340mm wide by 340mm deep.

OVEN OVERVIEW

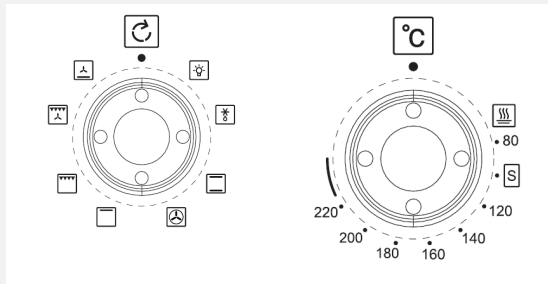

Turn the oven function control knob (shown on the left) clockwise or anti-clockwise to the cooking function required.

Turn the oven temperature control knob (shown on the right) clockwise to the temperature or setting required.

Turn the oven off by turning the function and temperature control knobs anti-clockwise back to the off position.







Note









The time of day must be set on the timer before the main oven can be used.

As this is a multi-functional oven, both a function and a temperature must be selected before the oven will start to heat up.

OVEN COOKING FUNCTIONS AND SETTINGS

Symbol	Description
	<p>Lamp only function (without heating on).</p> <p>Useful to provide extra visibility when wiping around the oven compartment.</p> <p>Leave the temperature selector control knob in the 'off' position.</p> <div style="background-color: #f0f0f0; padding: 10px; margin-top: 10px;"> <p>i Notice Please note - The oven heating indicator light will illuminate when the lamp only function is being used, even though the heating elements are not</p> </div>

Symbol	Description
	<p>switched on. This is normal, and does not indicate that the oven is heating up.</p>
	<p>Defrost function (without heating on).</p> <p>Use with the door closed to defrost frozen items such as bread and gateaux. Place the grill pan below the shelf to catch drips.</p> <p>Use with the door closed for proving dough prior to baking.</p> <p>Use with the door open for cooling cooked food prior to refrigerating.</p> <p>Leave the temperature selector control knob in the 'off' position.</p> <div data-bbox="392 797 1385 1128" style="background-color: #f0f0f0; padding: 10px; margin-top: 20px;"> <p>i Notice</p> <p>Please note - The oven heating indicator light will illuminate when the defrost function is being used, even though the heating elements are not switched on. This is normal, and does not indicate that the oven is heating up.</p> </div>
	<p>Conventional oven function.</p> <p>Useful for traditional baking and roasting.</p> <p>For best results, pre-heat the oven for up to 15 minutes, cook on one level only and use the middle shelf position. The oven will be a bit hotter at the top and a bit cooler at the bottom.</p>
	<p>True fanned oven function.</p> <p>Provides an even temperature distribution throughout the oven cavity.</p> <p>Use any suitable shelf position, and can bake on two or more levels simultaneously, remembering to allow space for baking to rise.</p> <p>Generally does not require pre-heating.</p> <p>Reduce the temperature by around 20°C and reduce the cooking time a little compared to conventional ovens.</p>

Symbol	Description
	<p>Top heat function.</p> <p>Often used towards the end of the cooking process to brown dishes like shepherd's pie, lasagne, cauliflower cheese, etc.</p> <p>For best results, place the food on a middle shelf position to avoid over-browning.</p>
	<p>Base heat with fan function.</p> <p>Useful for baking open pies and tarts or baking pastry cases, etc.</p> <p>For best results, pre-heat the oven for up to 15 minutes, cook on one level only and use the middle shelf position.</p>
	<p>Keep warm function (70°C).</p> <p>For keeping food warm prior to serving.</p> <p>Can be used for warming plates - place plates on the shelves.</p> <p>Select the fanned function  or conventional function  on the function selector.</p>
	<p>Slow cook function (100°C).</p> <p>For slow cooking of casseroles, stews, etc.</p> <p>Select the fanned function  or conventional function  on the function selector.</p>
80°C to 220°C	The temperature settings for the oven (80°C to 220°C).

GRILL COOKING FUNCTIONS AND SETTINGS





Important

When using the grill function, the door must be kept closed.



Tip

The grill is designed to be used with the door closed for quicker heat-up times and more efficient grilling.

Symbol	Description
	<p>Conventional grill function.</p> <p>Useful for toasting bread and grilling thinner meats, like bacon.</p> <p>Pre-heat for 3-5 minutes for best results.</p> <p>Use a suitable medium-to-high shelf position, but ensure that the food will not come into contact with the heating element.</p> <p>Use with the door closed.</p>
	<p>Fan-assisted grill function.</p> <p>Useful for circulating heat around thicker meats, like sausages and chicken pieces without the need to turn the food as often.</p> <p>Pre-heat for 3-5 minutes for best results.</p> <p>Use a suitable medium-to-high shelf position, but ensure that the food will not come into contact with the heating element.</p> <p>Use with the door closed.</p>

MAIN OVEN SHELF POSITIONS

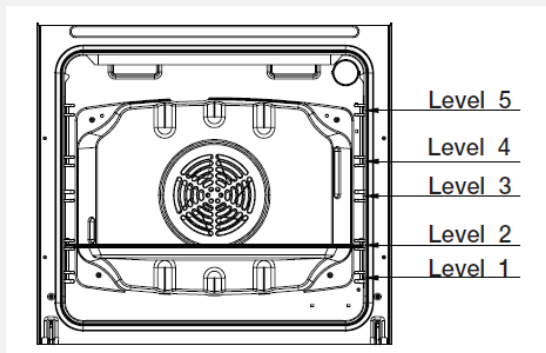

Note

- The oven may give off an unusual odour when first used, as the oils used to protect the oven enamel in storage are being burnt off.
- Ventilate the kitchen and heat the oven, without food in it, at 180°C for approximately two hours to remove any smell.
- Once the oven has cooled down, clean the oven interior, shelves, guides and grillpan with warm soapy water before using the oven to cook.

USING THE MAIN OVEN

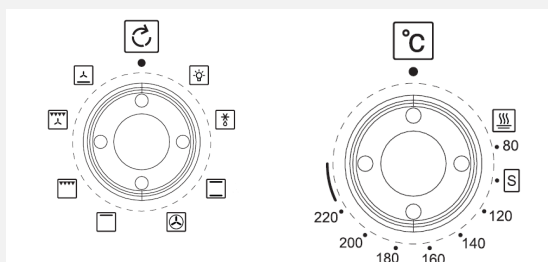

The oven function selector control.

The oven temperature selector control.



Caution

As this is a high efficiency oven, you may notice the emission of steam from the oven when the door is opened. Please take care when opening the door.

If you are used to cooking with a conventional oven you will find a number of differences to cooking with a fan oven which will require a different approach.



Warning

Accessible parts may be hot when the oven is used. Young children should be kept away.



Tip

Foods are cooked at a lower temperature than a conventional oven, so conventional recipe temperatures may have to be reduced.

SETTING A HEATING OPERATION

To start a heating operation, a cooking function must be selected with the left-hand control and a temperature must be selected with the right-hand control.

- Rotate the function selector control to the required cooking function.
- Rotate the temperature selector control to the required temperature.

To turn the oven off:

- Rotate the function selector control back to the 12 o'clock 'off' position.
- Rotate the temperature selector control back to the 12 o'clock 'off' position.

USING THE OVEN IN FANNED OVEN MODE



Tip

Preheating is generally not necessary as a fan oven heats up quickly.



Tip

There is no flavour transference in a fan oven, which means you can cook strong smelling foods such as fish at the same time as milder foods, such as an apple pie.



Tip

When batch baking foods that will rise during cooking - e.g. bread and cakes, always ensure that enough space has been left between the shelves to allow for the rise.

- There are no zones of heat in a fan oven as the convection fan at the back of the oven ensures an even temperature throughout the oven. This makes it ideal for batch baking - e.g. when planning a party, as all the items will be cooked within the same length of time.



Note

When 2 shelves are being used, it may be necessary to increase the cooking time slightly.



Note

Because the 2 oven shelves are wider than in many ovens, it is possible to cook 2 items per shelf side by side.



Note

When roasting meats, you will notice that fat splashing is reduced, which is due in part to the lower oven temperatures, and this will help keep cleaning of the oven to a minimum.



Note

There is no need to swap dishes onto different shelves part way through cooking, as with a conventional oven.

DEFROSTING AND COOLING IN THE MAIN OVEN

To defrost frozen foods, turn the oven function control to the defrost position, place the food in the centre of the oven and close the door.

Leave the oven temperature control in the off position.

To cool foods after cooking prior to refrigerating or freezing, turn the main oven function control to the defrost position and open the door.

Leave the oven temperature control in the off position.



Notice

Please nFAQote - The oven heating indicator light will illuminate when the defrost function is being used, even though the heating elements are not switched on. This is normal, and does not indicate that the oven is heating up.

DEFROSTING TIMES



Note

Small or thin pieces of frozen fish or meat- e.g. fish fillets, prawns or mince will take approximately 1-2 hours.



Note

Placing food in a single layer will reduce the thawing time.



Note

A medium sized casserole or stew will take approximately 3-4 hours.



Note

A 1½kg using/ 3lb oven ready chicken will take approximately 5 hours, remove the giblets as soon as possible.



Caution

BE SAFE:

Do not defrost stuffed poultry using this method.

Do not defrost larger joints of meat and poultry over 2kg / 4lb using this method.



Warning

Never cover the grill pan or grill trivet with aluminium foil, or allow fat to build up in the grill pan, as this creates a fire hazard.



Tip

For best grilling results use a suitable shelf position to move the food closer to the heat, while ensuring that the food will not come into contact with the grill heating element.

For best results, always pre-heat the grill for 3-5 minutes prior to use,

USING THE GRILL



Caution

Accessible parts may be hot when the grill is used- young children should be kept away.

USING THE GRILL

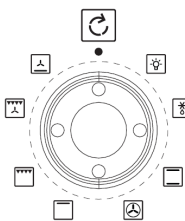

The oven function selector control.

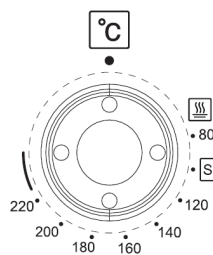

The oven temperature control.



Important

The grill door must be kept closed when the grill is used.



Notice

For the grill to heat up, you must select both the grill function on the function selector control and a temperature on the temperature control.



Warning

The top oven/grill door must be open when the grill is used for conventional grilling.

1. Turn the oven function control knob to the grill setting . Turn the oven temperature control knob to the required temperature (usually above 200°C). For best cooking results, we recommend that you preheat the grill for 3 to 5 minutes prior to use.
2. Push the grill pan in to position it under the grill.
3. To switch off return the function and temperature control knobs back to the off position.

GRILL PAN AND TRIVET

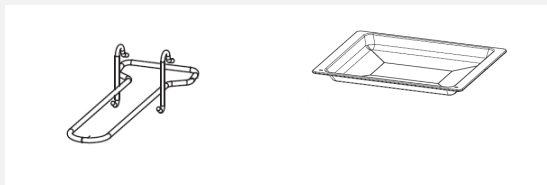

The trivet sits inside the grill-pan.

The holes and the sloping lip of the grill-pan go at the back.

The grill-pan handle clips over the front of the grill-pan. Ensure that the grill-pan handle prongs are at the top, and the wider support piece sits underneath the grill-pan.



Warning

The grill-pan handle is designed for sliding the grill-pan in and out. Do not attempt to carry the grill pan by the handle.

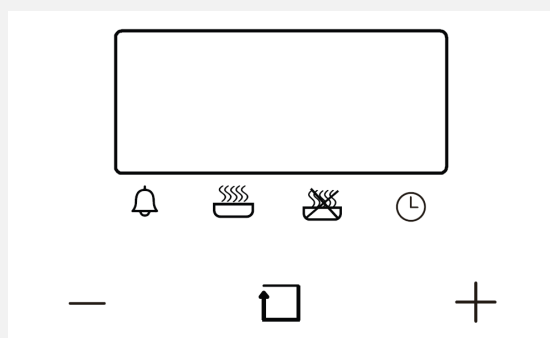

USING THE PROGRAMMABLE TIMER



Timer Symbols

Symbol	Description
	Minute minder
	Cooking duration time
	End of cooking time
	Time of day

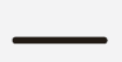
Timer Touch Controls

Touch Control Symbol	Description
	Minus key - to decrease time value
	Function key - to scroll through the timer functions

Touch Control Symbol	Description
	Plus key - to increase time value





Tip

Touching and holding the plus key/minus key makes the time value increase/decrease more quickly.

MANUAL MODE













- The main oven can be used manually, that is without the timer switching the main oven off automatically, or on and off automatically.
- The time of day must be set on the timer before using the main oven manually.

SETTING THE TIME OF DAY

















- When the cooker is first connected to the power supply the time display shows '12:00' and the bar above the clock symbol  flashes.
- Use the plus + and/or minus — keys to set the current time of day using the 24 hour clock.
- A few seconds after the last key touch, the time of day will be accepted and the main oven can be used manually.
- If you need to adjust the time of day, for example at the start and end of daylight saving time, touch the function key  repeatedly (usually four touches) until the bar above the clock symbol  flashes.
- While the bar is flashing, use the plus + and/or minus — keys to set the correct time of day using the 24 hour clock.

- A few seconds after the last key touch, the time of day will be accepted and the bar will stop flashing.

USING THE MINUTE MINDER













- The minute minder function sounds an alarm after a set time, to remind you to check, stir, turn or baste food, but does not switch the main oven off automatically.
- Touch the function key  repeatedly (usually one touch) until the bar above the bell symbol  starts to flash.
- While the bar is flashing, use the plus  and/or minus  keys to set the required minute minder time (up to 23 hours and 59 minutes).
- A few seconds after the last key touch, the minute minder duration time is accepted and starts counting down in the display. The bar above the bell symbol  shows solidly.
- When the minute minder duration time has elapsed, the alarm sounds. Touch the function key  to silence the alarm.
- If you wish to amend the minute minder duration time, touch the function key  repeatedly again (usually one touch) until the bar above the bell symbol  starts to flash. While the bar is flashing, use the plus  and/or minus  keys to set the updated minute minder time (up to 23 hours and 59 minutes). A few seconds after the last key touch, the updated minute minder duration time is accepted and starts counting down.
- If you wish to cancel the minute minder function, touch the function key  repeatedly again (usually one touch) until the bar above the bell symbol  starts to flash. While the bar is flashing, use the minus  key to take the minute minder time down to zero. A few seconds after the last key touch, the minute minder function is cancelled.





USING THE TIMER FOR SEMI-AUTOMATIC COOKING (SETTING DURATION TIME METHOD)

- With semi-automatic cooking, the timer will switch the main oven off after a set time, to help prevent over-cooking.
- Place the food in the main oven and select the required temperature.
- Touch the function key  repeatedly (usually two touches) until the bar above the dish symbol  starts to flash.
- While the bar is flashing, use the plus  and/or minus  keys to set the required cooking duration time (up to 10 hours).
- A few seconds after the last key touch, the cooking duration time is accepted, and starts counting down in the background. The bar above the dish symbol  shows solidly.
- When the cooking duration time has elapsed, the alarm sounds and the main oven heating is switched off. Turn the main oven control dial  back to the off position. Touch the function key  to silence the alarm.
- If you wish to check how much time is remaining, touch the function key  repeatedly again (usually two touches) until the bar above the dish symbol  starts to flash. While the bar is flashing, the remaining time will be displayed.
- If you wish to amend the cooking duration time, touch the function key  repeatedly again (usually two touches) until the bar above the dish symbol  starts to flash. While the bar is flashing, use the plus  and/or minus  keys to set the amended cooking duration time (up to 10 hours). A few seconds after the last key touch, the updated cooking duration time is accepted, and starts counting down in the background.
- If you wish to cancel the semi-automatic cooking function, touch the function key  repeatedly again (usually two touches) until the bar above the dish symbol  starts to flash. While the bar is flashing, use the minus  key to take the cooking duration time down to zero. A few seconds after the



last key touch, the semi-automatic cooking function is cancelled. Please note that the timer would not then turn the main oven off, and the main oven would need to be turned off manually by turning the main oven control dial  to the off position at the end of cooking.



USING THE TIMER FOR SEMI-AUTOMATIC COOKING (SETTING END TIME METHOD)

- With semi-automatic cooking, the timer will switch the main oven off after a set time, to help prevent over-cooking.
- Place the food in the main oven and select the required temperature.
- Touch the function key  repeatedly (usually three touches) until the bar above the crossed-out dish symbol  starts to flash.
- While the bar is flashing, use the plus  and/or minus  keys to set the required cooking end time (up to 23 hours and 59 minutes after the current time of day).
- A few seconds after the last key touch, the cooking end time is accepted. The bar above the crossed-out dish symbol  shows solidly.
- When the cooking end time arrives, the alarm sounds and the main oven heating is switched off. Turn the main oven control dial  back to the off position. Touch the function key  to silence the alarm.
- If you wish to check the cooking end time, touch the function key  repeatedly again (usually three touches) until the bar above the crossed-out dish symbol  starts to flash. While the bar is flashing, the cooking end time will be displayed.
- If you wish to amend the cooking end time, touch the function key  repeatedly again (usually three touches) until the bar above the crossed-out dish symbol  starts to flash. While the bar is flashing, use the plus  and/or minus  keys to set the amended cooking end time (up to 23 hours and 59 minutes after the current time of day). A few seconds after the last key touch, the updated cooking end time is accepted.
- If you wish to cancel the semi-automatic cooking function, touch the function key

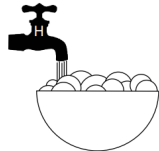
 repeatedly again (usually three touches) until the bar above the crossed-out dish symbol  starts to flash. While the bar is flashing, use the minus  key to take the cooking end time down to the current time of day. A few seconds after the last key touch, the semi-automatic cooking function is cancelled. Please note that the timer would not then turn the main oven off, and the main oven would need to be turned off manually by turning the main oven control dial  to the off position at the end of cooking.

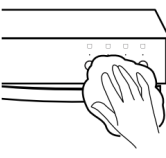
CLEANING YOUR APPLIANCE

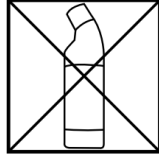
Cleaning: Do's	
	Use warm, soapy water
	Wipe the appliance with a damp cloth <ul style="list-style-type: none"> • Clean the cloth regularly
	Dry with a soft dry cloth

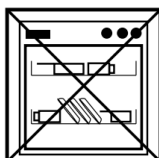
Cleaning: Don'ts	
	Don't use undiluted bleaches or Chloride products
	Don't use Wire Wool, Abrasive cleaners, Nylon pads or Steam Cleaners
	Do not wash the cast iron griddle, wok cradle, pan supports or telescopic sliders in the dishwasher



Note

Always switch off your appliance and allow it to cool down before you clean any part of it.



Note

Please take extra care when cleaning over the symbols on the control panel, as this can lead to them fading.



Note

Tips: Some foods can mark or damage the metal or paint work e.g; Vinegar, fruit juices and salt. Always clean food spillages as soon as possible.



Caution

It is important to clean your appliance regularly as a build up of fat can affect its performance or damage it and may invalidate your guarantee.



Caution

In addition to the above, do not use metal scrapers to clean the oven door glass, ceramic hob surface or any glass lids.

CLEANING AND CARE GUIDANCE

Area of appliance / material	Cleaning guidance	Example products
Catalytic liners	<ul style="list-style-type: none"> • Catalytic liners absorb splashes of fat during cooking, which are then burnt off at high temperatures. • Please still clean the oven floor, back panel and roof of the oven cavity as usual. • Catalytic liners need to be burnt off regularly. Approximately once per month, empty the oven of food, bakeware and shelves, and heat the oven to at least 200°C for about half an hour. This will help to burn off the grease. • If the liners become heavily soiled, wipe them with a soft sponge that has been soaked in warm soapy water. 	Washing-up liquid, if required.

Area of appliance / material	Cleaning guidance	Example products
Ceramic glass hotplates	<ul style="list-style-type: none"> • Clean with a ceramic hotplate cleaner/conditioner, applied with kitchen paper, following the instructions on the package. • Rinse with a damp, well-wrung out soft cloth. • Polish dry with a microfibre cloth. • If you do ever use a hob scraper to remove stubborn marks or deposits, please apply some ceramic hob cleaner onto the ceramic glass surface first, so that the hob scraper blade can glide across, at a 45° angle, without scratching the surface. • Please note that the cooker manufacturer cannot accept responsibility for scratches or damage to the ceramic glass surface caused by the use of a hob scraper. • Kitchen foil and spillages of sugary foods must not be allowed to bake onto the ceramic glass surface as they may cause pitting of the glass. • They must be removed immediately, even if the hob is still hot, taking care not to burn yourself. • Please be aware that pans with aluminium in the base can tend to leave marks on ceramic glass surfaces. • New hobs can sometimes show white 'bloom' marks which are related to manufacturing residues. • Apply some lemon juice to the glass surface and leave to soak for a while before cleaning with ceramic hob cleaner, rinsing and drying. • Do not clean ceramic hobs with washing-up liquid as it can sometimes leave behind a blue sheen. 	<ul style="list-style-type: none"> • Ceramic hob cream cleaner. • Microfibre cloths.

Area of appliance / material	Cleaning guidance	Example products
<p>Chrome oven shelves, grill pan trivets, shelf guides and telescopic sliders</p>	<ul style="list-style-type: none"> • Immerse a soft cloth in warm soapy water, wring out and wipe the shelves and shelf guides. • For heavier soiling, soak in warm soapy water, then clean with a non-scratch sponge. • Wave-shaped sponges can be useful for cleaning chrome shelves and grill pan trivets. • Wipe telescopic sliders with a damp cloth. Do not wash them in the dishwasher as the detergent will remove the lubricant from the runners which can prevent gliding and make them stiff. 	<ul style="list-style-type: none"> • Washing-up liquid. • Wave-shaped sponge.
<p>Control knobs and bezels</p>	<ul style="list-style-type: none"> • Wipe with a damp cloth. • On most models control knobs can be removed for more through cleaning in warm soapy water. • Please refer to the section for removing and replacing the knobs, bezels and the springs that go in between them. • It is a good idea to keep the user guide handy, or to take some photographs before you start removing the control knobs, so that you will be able to see which knob and bezel goes in which position when you are refitting them. • Do not attempt to remove control knobs from pyrolytic oven models, or from models with retractable control knobs. 	<ul style="list-style-type: none"> • Washing-up liquid.

Area of appliance / material	Cleaning guidance	Example products
Enamelled oven cavities and grill pans	<ul style="list-style-type: none"> • Wash with warm soapy water. • For heavier soiling, use a proprietary oven cleaner spray or gel, leave to work for as long as recommended in the instructions, then wipe away and rinse. • Do not allow oven cleaners to come into contact with stainless steel, aluminium or chrome parts, shelves, shelf supports, door seals, heating elements, or fascias with printed markings. • Do not allow fat to build up in grill pans and do not line grill pans with aluminium foil as this presents a risk of fire. • Grill pans can be lined with special non-stick PTFE cooking liners. • Non-stick PTFE cooking liners can reduce soiling in ovens. • Place these liners on the lower shelf, below the shelf where the food is being cooked, not on the floor of the oven cavity as this could block heat from the base element and cause damage. 	<ul style="list-style-type: none"> • Washing-up liquid. • Proprietary oven cleaner. • Non-stick PTFE cooking liners.
Glass door parts	<ul style="list-style-type: none"> • Wash with warm soapy water. • To remove grease from inner glass panels, use a proprietary oven cleaner spray or gel, leave to work for as long as recommended in the instructions, then wipe away and rinse. • Polish with a soft microfibre cloth. • Do not allow oven cleaners to come into contact with stainless steel, aluminium or chrome parts, shelves, shelf supports, door seals, heating elements, or fascias with printed markings. 	<ul style="list-style-type: none"> • Washing-up liquid. • Proprietary oven cleaner. • Microfibre cloths.

Area of appliance / material	Cleaning guidance	Example products
Grill compartment	<ul style="list-style-type: none"> • It is a good idea to leave the grill element on for a few minutes after finishing cooking to burn off any grease on the heating element. • Do not leave a grill-pan containing grease under the grill element during this procedure. • Once the grill compartment has cooled down, it can be wiped down with a damp wrung-out cloth which has been soaked in warm soapy water. • Wave-shaped sponges can be useful for cleaning chrome shelves, grill pan trivets, and for cleaning the roof of the grill cavity, getting in between the grill element. 	<ul style="list-style-type: none"> • Washing-up liquid. • Wave-shaped sponges.
Rubber door seals	<ul style="list-style-type: none"> • Clean with warm soapy water. • Do not attempt to clean fibreglass door seals on pyrolytic ovens. 	<ul style="list-style-type: none"> • Washing-up liquid.
Steel - fascia control panels, electric hotplate frames	<ul style="list-style-type: none"> • Clean steel parts with warm soapy water and a soft sponge. • Do not scrub fascias / control panels as the markings could start to wear away. • Rinse with warm water and a soft cloth. • Polish dry with a microfibre cloth. 	<ul style="list-style-type: none"> • Washing-up liquid. • Microfibre cloths.

APPLIANCE MAINTENANCE

CHANGING THE LIGHTBULB

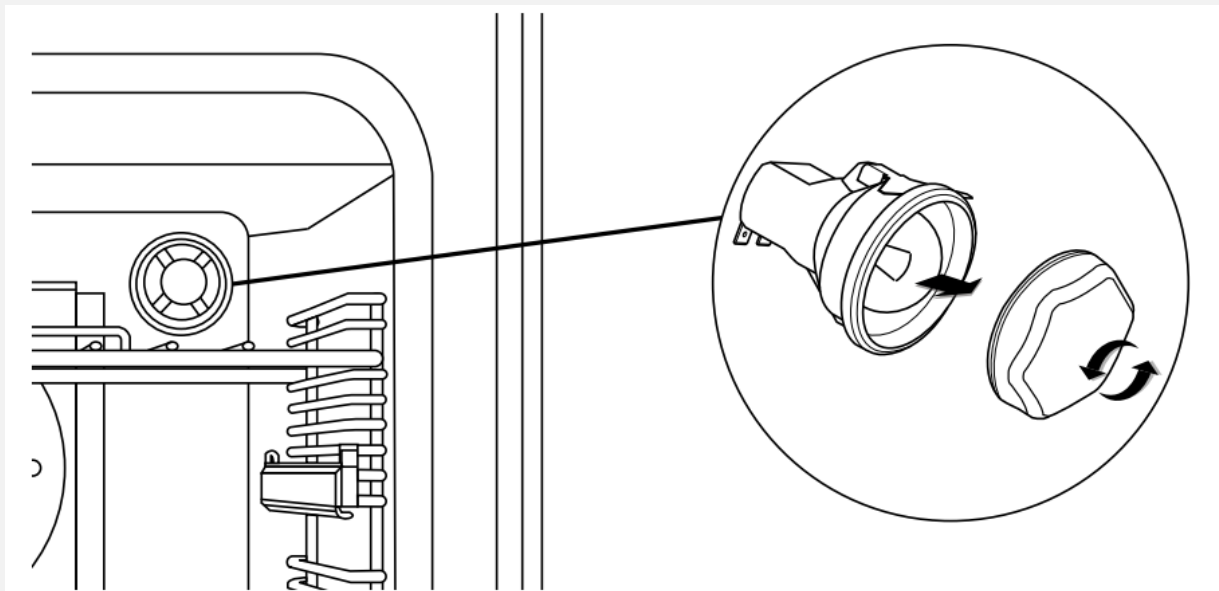

1. Switch the cooker off at the wall. Remove the oven shelves, grill pan and air fry tray.
2. Unscrew the lens cover by turning anticlockwise.
3. Remove the old bulb and replace it with a new one. Handle the new bulb with a piece of kitchen paper as skin oils can damage halogen bulbs.
4. Replace the lens cover and put the oven shelves back.



Warning

Switch off the power before you change the light bulb.



Note

Not all appliances have the same number and type of bulbs. Before you replace your bulb, check to see what type you have. Usually a 25 watt G9 halogen capsule bulb - part number 082650920.

Please remember that bulbs are not covered by the manufacturer's warranty.

OVEN SHELVES

The oven shelves use anti-tip notches to prevent them being accidentally pulled out fully with hot food and cookware on them, to help prevent accidents.

Shelves With Anti-Tip Notches.

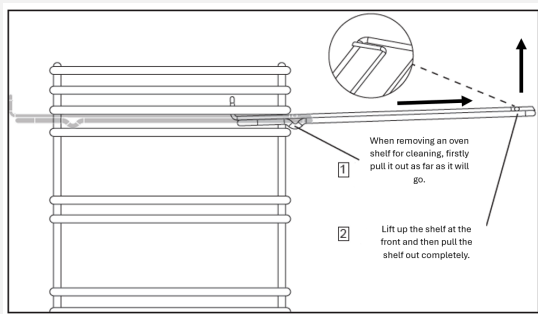

To remove the shelves fully, for cleaning or to reposition them, pull the shelf out as far as it will go, then lift upwards at the front to pull out fully.

Shelves.

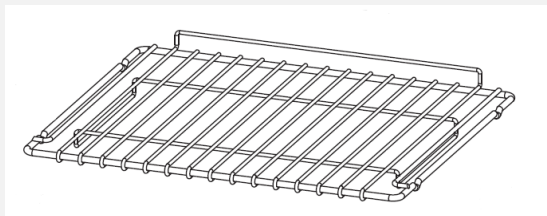

When inserting the shelves into the shelf guides, ensure that the upstand piece is at the back of the shelf and is pointing upwards. (Not all shelf types have an upstand).

The anti-tip notches should always be pointing downwards, and should be towards the back of the shelf.

Shelf Guides.

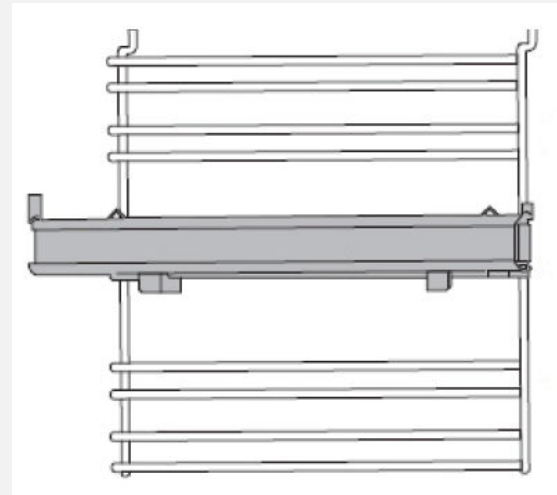

Caution

Each shelf guide position consists of an upper and a lower wire. Please insert the shelf between the two wires, and not sitting on top of the upper wire.

REMOVING AND REPLACING SHELF GUIDES

The shelf guides have lugs which attach into holes on the side of the oven cavity. The shelf guide wires at the bottom and top clip into retainers to keep the shelf guides in position. The retainers look like small cotton reels or bobbins which are attached to the side of the oven cavity,



To remove the shelf guides for cleaning, firstly please remove the shelves and/or grill pan

as appropriate. Gently stretch the shelf guide wire at the bottom, pushing up and away from the retainer (or pushing down and away from the retainer at the top of the guide) to release the guide from the retainer.



The shelf guide can then be pulled away from the side of the oven cavity. The shelf guide lugs will come out of the holes in the side of the cavity.



The shelf guide is replaced in the opposite manner. Insert the lugs into the holes on the side of the oven cavity. Then, gently stretch the guide wire at the top to loop it under the upper retainer. Then gently stretch the guide wire at the bottom to loop it over the lower retainer.

REMOVING AND RE-FITTING CONTROL KNOBS, SPRINGS AND BEZELS

- The control knob assembly consists of the knob at the front, a bezel with markings around the knob, and a spring between the knob and the bezel.

- For cleaning, the bezels can be carefully slid forward to allow easy cleaning of the fascia control panel behind with a cloth.
- The bezels will spring back into position when you let go.
- For more thorough cleaning, the knobs, bezels and springs can be removed as follows.
- Firstly, please take a moment to note the positions of the different types of bezels on the cooker, take some photographs or have the appliance user guide handy. This will help you to replace the controls in the correct positions after cleaning.
- Ensure that all of the control knobs are in the 'off' position, and that the cooker is turned off at the wall.
- Push the control knob in towards the bezel.
- Then, holding the knob and bezel together, pull them both towards you and off the cooker spindle.
- Be careful not to lose the spring, or the small silver clip which is inside the control knob shaft.
- To re-fit the control knobs, bezels and springs after cleaning, please follow these steps:
 - Place the bezel face up on a surface.
 - The flat side of the D-shaped hole and the printed dot for the 'off' position should be at the top.
 - Place the spring over the hole in the middle of the bezel.
 - Ensure that the knob is facing upwards, with the indicator mark at the top.
 - Place the knob firmly over the spring, ensuring that the shaft on the back of the knob is located through the middle of the spring.
 - The flat side of the D-shaped shaft at the back of the knob should be lined up with the flat side of the D-shaped hole in the middle of the bezel.
 - Press down on the knob to push it into the bezel and keep it held down.
 - The flat side of the D-shaped shaft at the back of the knob should be facing upwards.
 - While holding the knob and bezel together, push the control knob assembly on to the cooker spindle.
 - The cooker spindle is also D-shaped, so ensure that the flat side of the D-shaped

shaft at the back of the knob is aligned with the flat side of the spindle.

- The control knob assembly has now been correctly installed and the controls can be used as normal.

REMOVING THE INNER GLASS PANEL

The inner glass door panel can be removed for cleaning.

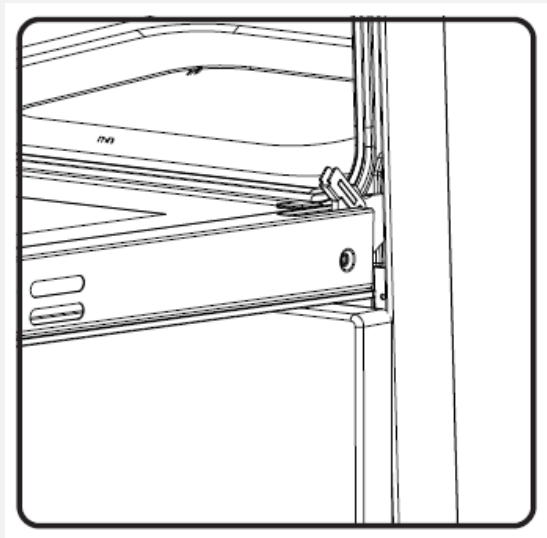

Open the oven door fully to a 90° angle.

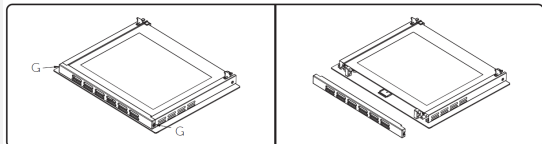

Locate the screws (key G) on either side of the metal retaining strip along the top of the door assembly.

Remove these screws with a cross-head screwdriver, being careful not to misplace them.

Pull the metal retaining strip forwards and off the door assembly.

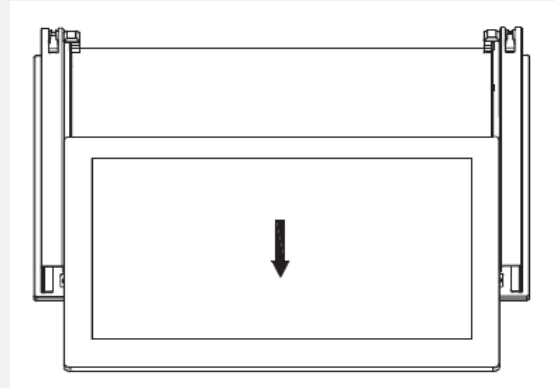

The inner glass panel can now be slid out for cleaning.



Caution

Caution - when the weight of the inner glass panel is removed from the door assembly, the door assembly may spring up.

It is advisable to have a second person available to hold the door assembly down gently by the door handle while you are removing and re-inserting the inner glass panel.

When replacing the inner glass panel, ensure that the shiny side is facing upwards towards the heat of the oven.

After sliding the inner glass panel back into position, place the metal retaining strip back on to the door assembly and secure it in place with the screws.



Caution

Do not use the oven with the inner glass panel missing as the outer door could get very hot.

DOOR REMOVAL

If required, the oven door can be removed from the body of the cooker.

This can make it easier when removing and cleaning the inner glass panel and door parts, and can give easier access when cleaning the oven cavity.



Caution

Oven door assemblies can be heavy - it is advisable to have two people available to assist with this procedure.

Never carry a door assembly by the door handle - risk of breakage and injury.

Please ensure that you are comfortable with the procedure for removing and replacing the oven door before proceeding. A charge would have to be made to request an engineer visit to re-fit the door, even if the appliance is still under the manufacturer's warranty.

Please wear protective gloves during this procedure.

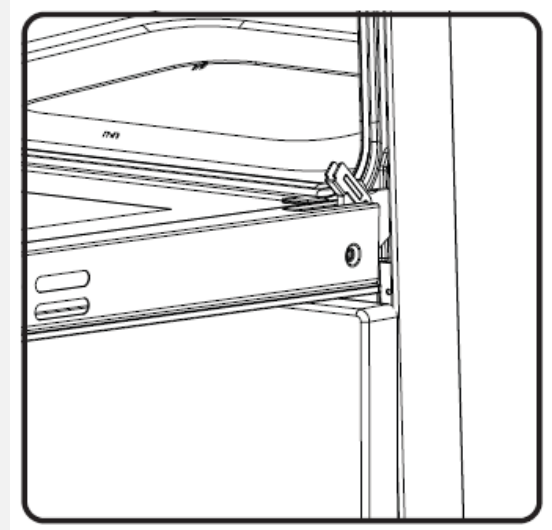

On each hinge is a locking latch (key A). Lift each locking latch upwards and towards you as far as they will go (towards position B).

The locking latches may be stiff, especially if the door has not been removed before, and the use of pliers may be necessary.

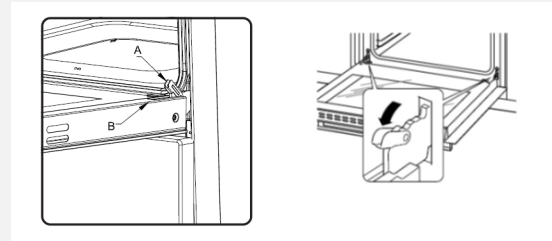

Placing a hand on either side of the door assembly, partially close the door to about a 30° to 45° angle.

Then, keeping a hand on either side of the door assembly, carefully lift the door assembly up and away from the body of the cooker.

Open the oven door fully to a 90° angle.

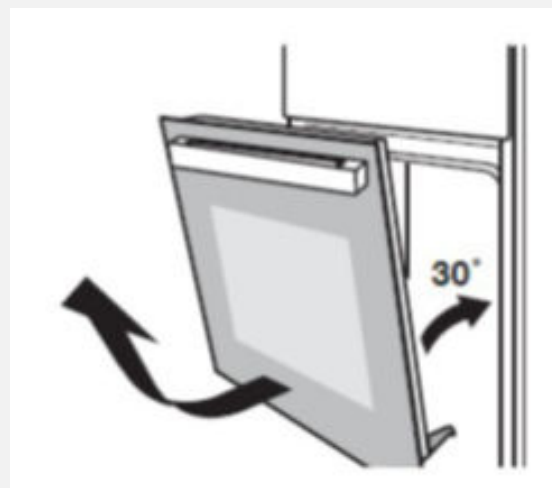

Place the door assembly down on a soft, flat surface, for example a thick bath towel laid out on a table.



Caution

Do not attempt to lift or carry the door assembly by the door handle - risk of breakage and injury.

Keep fingers and all parts of the body clear of the hinges while the door assembly is off the cooker - risk of injury.

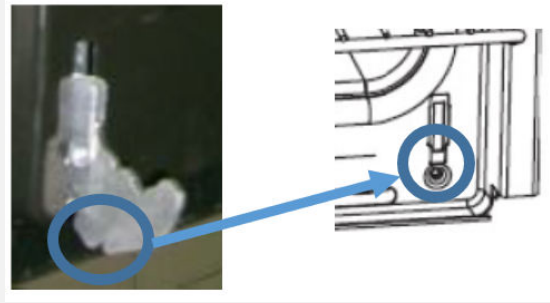

Open the door fully to a 90° angle.

Lift the hinge locking latches and push them away from you as far as they will go until they are securely back in their original position,

When refitting the door, carefully carry the door assembly with one hand on either side of the door assembly.

Align the door assembly with the body of the cooker at approximately a 30° to 45° angle.

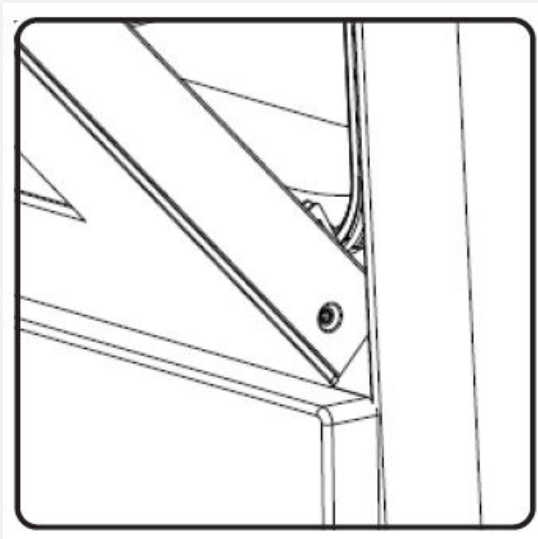

On each hinge is a notch which needs to be located over the lip of the hinge receiver on the body of the cooker.

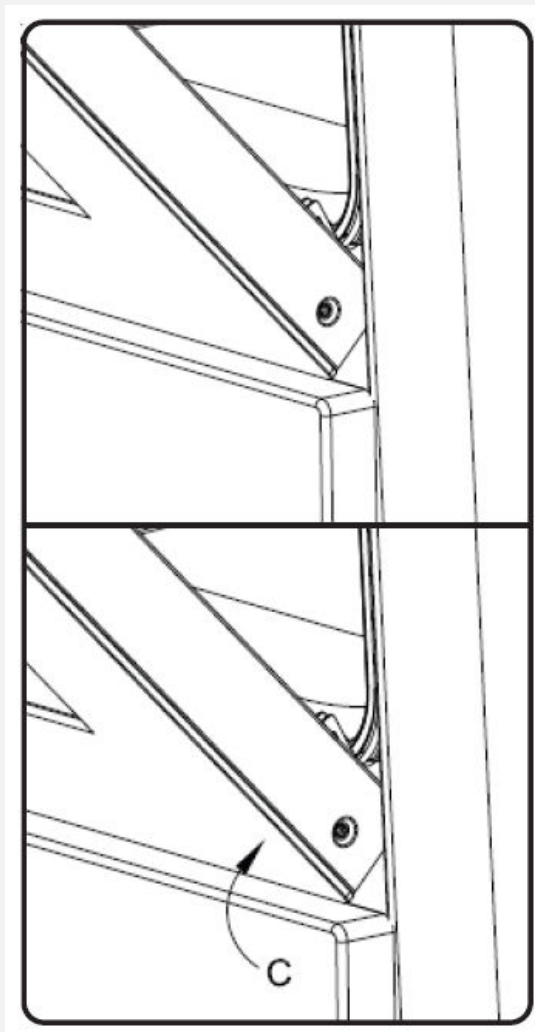

Close the door fully as usual.

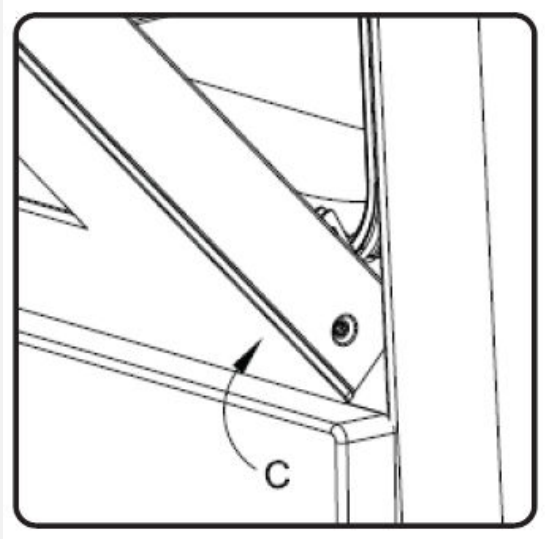



FAQ's

Please refer to these frequently asked questions about your appliance as they may help to resolve any minor issues.

Should any issue persist after following this advice, please contact the service office for further assistance.

<p>Can I remove the inner glass on the doors for cleaning?</p>	<p>The inner glass panels are removable for cleaning, however this does involve removing the screws from the retaining strip along the top of the door first.</p> <p>For routine cleaning we recommend leaving the glass panels in situ.</p>
<p>There's been a power failure and the cooker won't work- what should I do?</p>	<p>Switch off the electricity supply to the cooker at the wall switch.</p> <p>When the power supply is restored switch the electricity supply back on at the wall and re-set the timer clock to the correct time of day.</p>
<p>Why is there some warm air coming out of the sides of the doors?</p>	<p>This is normal. The doors have some side vents which allows a small amount of this heat to be expelled at the door sides to help keep the door surfaces keep cool.</p>
<p>How do I attach the grill pan handle to the grill pan?</p>	<p>Attach the handle to the grill pan making sure the prongs are at the top and the wider support piece sits underneath the grill pan.</p>
<p>Why can I not remove the shelves completely for cleaning?</p>	<p>The shelves have 'anti-tip notches' which prevent the shelves being accidentally pulled out completely with cookware on the shelf, to help prevent accidents.</p> <p>To remove the shelves fully for cleaning, pull the shelf out, then lift upwards at the front to pull out fully.</p>
<p>When cleaning, I found a small hole in the top of the main oven cavity, is this meant to be there?</p>	<p>This is normal. This is a vent which allows excess steam and pressure to vent out of the rear of the appliance during cooking. The oven can be cleaned as normal.</p>

<p>The induction hob zones are not responding when I turn the control knob.</p>	<p>Please ensure that the induction hob has been powered up into standby mode, by touching the power key  on the hotplate glass for a few seconds until the dashes appear, before turning the hob control knob to the required power level.</p> <p>Please check that the hob child-lock has not been activated in error (with 'LO' appearing in the hob display). If it has, please deactivate the hob child-lock by turning the front-left cooking zone control knob to the left (anti-clockwise) and holding it at the child lock symbol  for about 3 seconds, until a beep sounds and 'LO' disappears from the hob display.</p>
<p>The hob induction zones seem to pulse on and off - is this normal?</p>	<p>Yes, this is perfectly normal and will not affect cooking results.</p> <p>Induction hobs are different to ceramic hobs in that they don't have heating elements underneath the glass.</p> <p>Instead there are induction coils which create a magnetic field when an electric current is passed through them.</p> <p>The magnetic field causes the magnetic base of the pan to vibrate and the resulting friction generates heat in the pan.</p> <p>The electronics will switch the induction coil on and off at intervals, in order to maintain the requested power level.</p> <p>So on lower power settings, the coil will be on for shorter periods and will rest off for longer periods. On higher power settings, the coil will be on for longer periods and rest off for shorter periods.</p> <p>This is perfectly normal and is necessary to maintain the overall power setting requested and to prevent the pan overheating. This will not affect the overall cooking results in any way.</p> <p>As a general rule, a good test is to heat a pan containing 1 litre of water at power level 9. If the water starts to bubble and boil within approximately 5 minutes then you can be sure that the induction hob is working correctly.</p>

There are clicking / buzzing / humming sounds when I use the induction hob - is this normal?

Yes; you may hear some soft clicking when the induction coil is switched on or off, and some soft buzzing relating to the friction creating heat in the pan.

Induction hobs also use cooling fans to help protect and prolong the working life of electronic components and so you may hear a fan running on for a while after you have finished cooking.

To minimise noises, please ensure that the base of the pan and the ceramic glass are dry, as if the base of the pan or ceramic glass is wet this may create a 'crackling' sound.

Any noises may be more noticeable at higher power settings than lower power settings.



Different types of pans can create different levels of noise. Generally-speaking, the greater the quantity of magnetic material in the base of the pan, the quieter it will be in operation.



As stainless steel is not magnetic, when stainless steel pans are made for induction hobs they are given a magnetic base containing layers of different materials. (This is why a magnet will stick to the base of the pan but not to the sides of the pan). This allows induction hob-compatible pans to be produced and sold at a reasonable price, but they do tend to be noisier in operation because of the vibrations which occur where the different material layers touch.

On the other hand, a pan made from cast iron is already magnetic and does not need a separate magnetic base adding to it, and so tends to produce quieter sounds in operation.

When shopping for pans, it can be useful to take along a fridge magnet. If the side of the pan and the base of the pan is magnetic, it is likely to be quieter in operation. If the side of the pan is not magnetic, but the whole diameter of the base is magnetic, then it will work on an induction hob but it is likely to be louder in operation.

<p>I can hear the sound of a fan running after cooking - is this normal?</p>	<p>Yes, it is normal to hear the sound of the cooling fan running after switching the ovens or the induction hob off.</p> <p>The cooling fan(s) help to cool the appliance down and help to keep exterior parts, such as control knobs and door handles, cooler during operation.</p> <p>The cooling fan(s) may run on for up to about 30 minutes after cooking, but they don't use very much electricity.</p> <p>Please do not switch the cooker off at the wall until the cooling fan has stopped completely, to prevent the risk of heat damage to control knobs and control panels.</p>
<p>Why is the main oven not working?</p>	<p>Please check that there is power to the cooker and the timer display is lit up.</p> <p>Please ensure that the time of day has been set on the timer.</p> <p>Please ensure that there are no bars flashing on the timer display. If they are flashing, please press the middle function key  to return the timer to manual mode.</p> <p>Then try turning the main oven function selector control to a cooking function and the temperature selector control to a temperature as usual.</p>
<p>The oven heating indicator light comes on when I use the defrost function or the lamp only function - is this normal?</p>	<p>Yes, this is normal. Because of the way that the oven controls are configured, the oven heating indicator light will illuminate when the defrost or lamp only functions are being used, even though the heating elements are not switched on. This is normal and does not indicate that the oven is heating up.</p>
<p>The installer is having difficulty adjusting the cooker height to the level of adjacent worktops, when the worktops are a bit lower than standard 900mm height.</p>	<p>The levelling feet are supplied with two locknuts, which is ideal when adjusting the cooker height to worktop heights between 900-930mm.</p> <p>When adjusting the cooker height to worktop heights a little lower than 900mm, the installer should please remove one of the locknuts from each foot to be able to adjust the height of the cooker lower.</p>

<p>I have found two hooks inside the oven with the shelves - what are they for?</p>	<p>These new models have two stability chains fitted to the back of the cooker.</p> <p>The hooks are provided to be drilled into the wall behind the cooker to attach the stability chains to.</p> <p>If you already had hooks in the wall from your previous cooker, the installer may have re-used those hooks which is why the new ones are still in the packaging.</p> <p>If in doubt, please consult your installer.</p>
<p>The main oven does not seem to return to manual mode after I have used automatic cooking.</p>	<p>When the oven heating switches off at the end of semi-automatic cooking or fully-automatic cooking, turn the main oven control knob back to the off position.</p> <p>Then press the middle function key  on the timer to silence the alarm and return the timer to manual mode.</p>
<p>The grill seems to be taking a long time to cook.</p>	<p>Please ensure that the door is kept closed during grilling to keep the heat in for better grilling results and energy-efficiency.</p> <p>For best results , please pre-heat the grill for 3-5 minutes before use, and position the food on the grill pan trivet using a suitable shelf position which brings the food close to the grill element without the food touching the grill element.</p>
<p>The oven lamps are not working.</p>	<p>Please refer to the section on changing the light bulb. [40]</p>
<p>The oven seems to be overheating.</p>	<p>Please ensure that the oven control knob has been turned to the required temperature.</p> <p>When using the oven in conventional mode , place the food on the middle shelf position. The oven will be hotter at the top.</p> <p>When using the oven in fanned oven mode , please remember that the temperature will need to be reduced by about 20°C and the duration reduced a little compared to conventional oven cooking instructions.</p>

<p>The oven seems to be under-heating.</p>	<p>Please ensure that the oven control knob has been turned to the required temperature.</p> <p>When using the the oven in conventional mode , place the food on the middle shelf position. The oven will be cooler at the bottom.</p> <p>When using the oven in conventional mode , pre-heat the oven for 10-15 minutes prior to use.</p> <p>Check that the door is closing and sealing well, and that the door seal is in good condition.</p> <p>Ensure that any additional tins and trays which are not being used are removed from the oven before cooking.</p> <p>Use good quality bakeware with a dull, matt finish; avoid bakeware with a shiny silver finish.</p>
<p>There is a strange smell / a little smoke produced when using the ovens for the first time.</p>	<p>This is normal. The oils used to protect the oven cavities during storage of the appliance are being burnt off.</p> <p>Heat the ovens empty for around 30 minutes at around 200°C to allow the smell / smoke to dissipate. Open the kitchen window(s) during this procedure.</p>
<p>One control knob appears to be missing on delivery of the new cooker.</p>	<p>For packaging reasons, to protect the cooker in transit, the left-hand-side control knob, spring and bezel are packaged inside the oven cavity for the installer to fit once the cooker has been unpackaged.</p> <p>Please ensure that this control knob, spring and bezel is fitted before attempting to use the cooker.</p> <p>Please see the Removing and re-fitting control knobs, springs and bezels [42] section for further details.</p>

For more useful information and FAQs, please visit our online FAQ section at: [Freestanding Cooker FAQs](#)

KEY PARTS AND OPTIONAL ACCESSORIES

Please see below for useful part numbers for your cooker, in case you require a replacement part or wish to purchase additional shelves or optional telescopic sliders, for example.

For any queries relating to parts missing on delivery of a new cooker, or relating to replacement parts during the manufacturer's warranty period, please contact our customer

care team using the telephone number on the back cover.

To purchase additional shelves, sliders, consumables or parts outside of the manufacturer's warranty period, please refer to the Spare Parts section of our website - the website address is on the back cover.

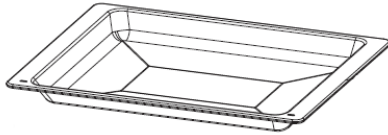
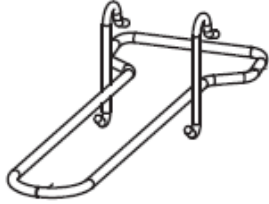
Part	Part Number	Notes
Clip-in door seal - main oven	2030400003	Clips in - does not usually require an engineer service visit.
 Grill pan	30304200002	Quantity 1 is supplied with the cooker. Can be used as a grill-pan, baking tray or roasting tin.
 Grill pan handle	30400800002	Quantity 1 is supplied with the cooker.

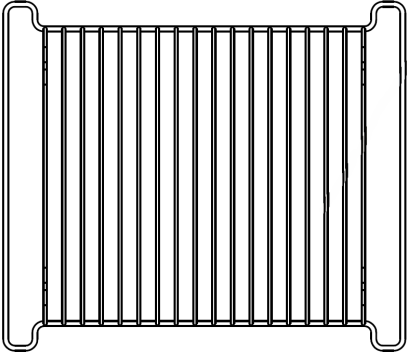
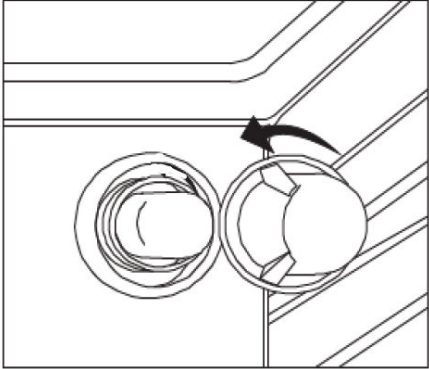
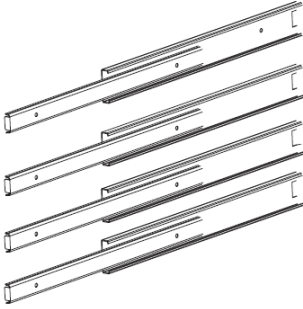
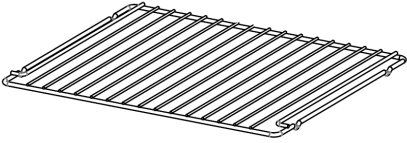
Part	Part Number	Notes
 <p>Grill pan trivet</p>	<p>3040100003</p>	<p>Quantity 1 is supplied with the cooker.</p>
 <p>Lamp bulb</p>	<p>082650920</p>	<p>Type - 25 watt G9 halogen capsule bulb.</p> <p>Please note that replacement bulbs are not covered under the manufacturer's warranty.</p>
 <p>Telescopic Sliders</p>	<p>Left hand side slider: 1 x 094109802</p> <p>Right hand side slider: 1 x 094109803</p> <p>You need 1 x 094109802 and 1 x 094109803 to make a pair.</p>	<p>Can be purchased as an optional extra.</p> <p>Can be used in the main oven.</p>
 <p>Shelf</p>	<p>30400100003</p>	<p>Quantity 2 are supplied with the cooker.</p> <p>Can be used in the main oven.</p>

LOCATING THE MODEL AND SERIAL NUMBERS

- Please open the bottom / main oven door to locate the data badge on the front frame, close to the door seal.
- Please quote the model number and serial number should you ever require an engineer service visit or need to order spare parts.
- The model number (also known as the SKU number) is 9 digits long, beginning with 44...
- The serial number is printed as a string of 17 digits - the first 8 digits are the serial number and the remaining 9 digits are the model number.

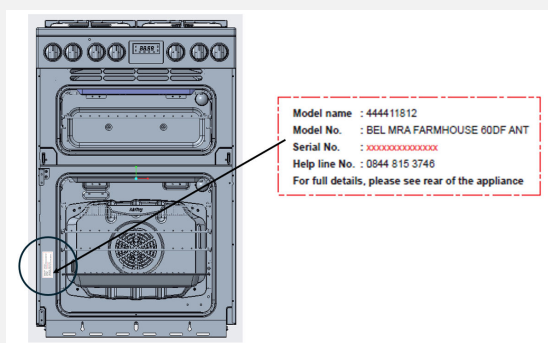

Tip

It is a good idea to take a photo of the data badge or to make a written note of the model number and serial number on your quick start guide.

TECHNICAL DATA



Warning
This cooker must be earthed.

Data badge	Lower part of the front frame
Appliance class	Class 1 - freestanding cooker
Electrical supply	220 - 240V ~1N ~ 50 Hz or 380 - 415V ~ 3N ~ 50-60Hz
Load	9365W - 9775W (Induction Unit 7200W)
Standard Oven Light	25W

Hob Top Hotplate	Electrical Supply	Zone Load (W)
Electric	230V	Left hand front 2300W (boost to 3000W)
		Left hand rear 1200W (boost to 1500W)
		Right hand front 1200W (boost to 1500W)
		Right hand rear 1800W (boost to 2100W)
		N/A
		N/A

Appliance Electrical Supply	Oven Cavity & Function Load (W)
230V	Main oven: conventional oven mode: 2047W; fanned oven mode: 1865W; conventional grill mode: 2347W; fanned grill mode max: 2365W
	N/A
	N/A

ENERGY DATA TABLE

Regulation (EU) 66/2014:

Model Identification: BEL FSA VS SGL 60EI RTY	
Brand:	Belling
Size:	60cm

Energy Efficiency For Oven

Oven	Cavity 1
Mass of the appliance (M): 45,0 kg	
Number of cavities: 1	
Type of oven:	Electric oven
Heat Source per cavity:	Electricity
Volume per cavity (V):	68 Litres
Energy consumption (electricity consumed) per cycle in conventional mode ($EC_{\text{electric cavity}}$):	0,77 kWh
Energy consumption (electricity consumed) per cycle in fan-forced convection mode ($EC_{\text{electric cavity}}$):	0,76 kWh
Energy efficiency index per cavity (EEI_{cavity}):	90,5
Energy efficiency class:	A

Energy Efficiency For Hob

Hob	
Type of hob:	Electric
Number of cooking zones and/or areas:	4
Heating technology:	Induction cooking zones

Electric Zone:	Location:	Useful surface area per electric heated cooking zone:	Energy consumption per cooking zone or area ($EC_{\text{electric cooking}}$):
Zone 1	Front-left	21,0 cm diameter	190,2 Wh/kg
Zone 2	Back-left	16,0 cm diameter	194,2 Wh/kg
Zone 3	Front-right	16,0 cm diameter	194,2 Wh/kg

Zone 4	Back-right	18,0 cm diameter	191,3 Wh/kg
Zone 5	N/A	N/A	N/A
Zone 6	N/A	N/A	N/A

Energy consumption for the hob ($EC_{\text{electric hob}}$):	192.475 Wh/kg
--	---------------

Energy consumption measured in accordance with EN 60350-1 and EN 60350-2

ENERGY SAVING TIPS FOR HOBS



Tip

Use pans with flat bases.

Use pans which are suitably-sized for the size of the cooking zone.

Use pans with lids.

Minimise the amount of liquid or fat when cooking.

When liquid starts boiling, reduce the power level to a simmer.

Using a pan with a base diameter a little larger than the diameter of the cooking zone gives the most energy-efficient cooking results.



Tip

Cook separate meals together, if possible.

Keep the pre-heating time as short as possible.

Do not elongate the cooking time.

Do not forget to turn the oven off at the end of cooking.

Do not open the oven door during the cooking process.

If the oven has a programmable timer, use the timer to switch the oven heating off at the end of cooking.

If cooking for longer periods, turning the oven heating off 10 minutes before the end of cooking can save energy by using the residual heat to finish the cooking process. Always ensure that food is thoroughly cooked through.

ENERGY SAVING TIPS FOR OVENS

SERVICE CONTACT DETAILS

Ireland	Tel: +353 (0) 1 8428222 Service e-mail: serviceireland@glendimplex.com Spare parts enquiries e-mail: sparesireland@glendimplex.com www.glendimplexireland.com Glen Dimplex Ireland UC, Airport Road, Cloghran, Co. Dublin, K67 DT89
United Kingdom	Stoves Service Tel: +44 (0) 344 815 3740 www.stoves.co.uk Belling Service Tel: +44 (0) 344 815 3746 www.belling.co.uk Glen Dimplex Home Appliances, Element, Temple Court, Risley, Warrington, WA3 6GD

This document relates to these models:

Model Number:	Model Description:
444412053	BEL FSA VISION SGL 60Ei BLK
444412054	BEL FSA VISION SGL 60Ei BSS

**Glen Dimplex Home Appliances, Element, Temple Court, Risley,
Warrington, WA3 6GD.**

0344 815 3746

www.belling.co.uk

GDHA Part Number: UG FS BEL 60S EI UK V2

