



**Brugsvejledning** DK/NO (2-16)

**Bedienungsanleitung** DE (17-32)

**User Manual** UK (33-46)

**Mode d'emploi** FR (47-62)

**Manual de usuario** ES (63-77)

**Manuale d'uso e manutenzione** IT (78-92)



## **Aduro 5.1**

**EN13240 – NS3058**

**[aduro.dk](http://aduro.dk) / [aduro.no](http://aduro.no) / [adurofire.de](http://adurofire.de) / [adurofire.com](http://adurofire.com)  
[adurofire.se](http://adurofire.se) / [aduro.fr](http://aduro.fr) / [aduro.es](http://aduro.es) / [aduro.it](http://aduro.it)**

## Congratulations on your new Aduro Stove!

To get the best possible experience and benefit from your new Aduro fireplace insert, it is important that you read the user manual thoroughly through before you install the stove and start using it. Errors or incorrect settings can cause hazardous conditions and/or poor operation.

For further information, please go to [www.adurofire.com](http://www.adurofire.com).

### 5-year warranty – Free online registry

You have the opportunity to extend the warranty on your fireplace insert from two to five years for free. All you need to do is register the stove at [www.adurofire.com/warranty](http://www.adurofire.com/warranty). The deadline for registering is five months from the date of purchase.

### Production number

The wood stove has a production number on the rating plate on the back of the stove. Besides this the number is also stamped inside at the bottom of the door. We recommend that you note down this number in the box below before mounting the wood stove. For the purposes of the guarantee and for other enquiries, it is important that you are able to quote this number.

**Enjoy!**

#### HOW TO SUCCEED WITH YOUR NEW WOOD STOVE

In our customer service center [Aduro Customer Service](#) you will find tips and tricks on how to succeed with your new Aduro wood burning stove. Here you will have direct access to interesting content about installation and maintenance of your stove as well as support related information. Find us [here](#) and make the most of your Aduro wood stove.



# 1. General

## 1.1 Compliance

Aduro 5.1 complies with the EN13240 European standard as well as the NS3058 Norwegian standard and is thereby approved for installation and use in Europe. At the same time, the manufacturing process is subject to external quality control. DoP (Declaration of Performance) can be downloaded at [www.adurofire.com/download](http://www.adurofire.com/download).

## 1.2 Technical data

<b>Aduro 5.1</b>	<b>Data</b>
Nominal power	7.0 kW
Flue outlet, diameter	Ø15 cm top/rear
Measurements (HxWxD)	57.4 x 63.5 x 46 cm
Distance from centre of exhaust branch to rear edge of stove	19 cm
Weight	77 kg
Material	Sheet iron
Fuel	Wood and wood briquettes
Max wood length	40 cm
Convection stove	✓
Primary, secondary, and tertiary air supply	✓
Air-wash system	✓
Ashpan	✓
Energy efficiency	78.7 %
Energy efficiency index	105.1
Energy efficiency class	A
Chimney draft	12 Pa
Maximum combustion amount per hour (wood)	Approx. 3.4 kg
Heat rating in buildings with - Optimum insulation - Average insulation - Inadequate insulation	175 m <sup>2</sup> 115 m <sup>2</sup> 70 m <sup>2</sup>

## 1.3 Transportation

When taking your fireplace insert home, please ensure that it travels in an upright position. If you wish to lay it flat, it is important that you remove all loose parts from the combustion chamber (cast iron grate and loose fireproof tiles) and remove the ashpan. Please use wood from the packaging for the first use. The plastic packaging should be discarded.

## 2. Installation of the stove

You are welcome to install your fireplace insert yourself – but we strongly recommend that you consult your chimney sweep before you begin the installation. It is important to ensure that all local rules and regulations, including ones relating to national and European standards, are complied with when installing this device. Your dealer can also provide you with installation advice. Remember, it is your responsibility that rules in force are complied with.



**You may not begin to use the stove until it has been inspected and approved by your local chimney sweep.**

Illustration Aduro 5.1

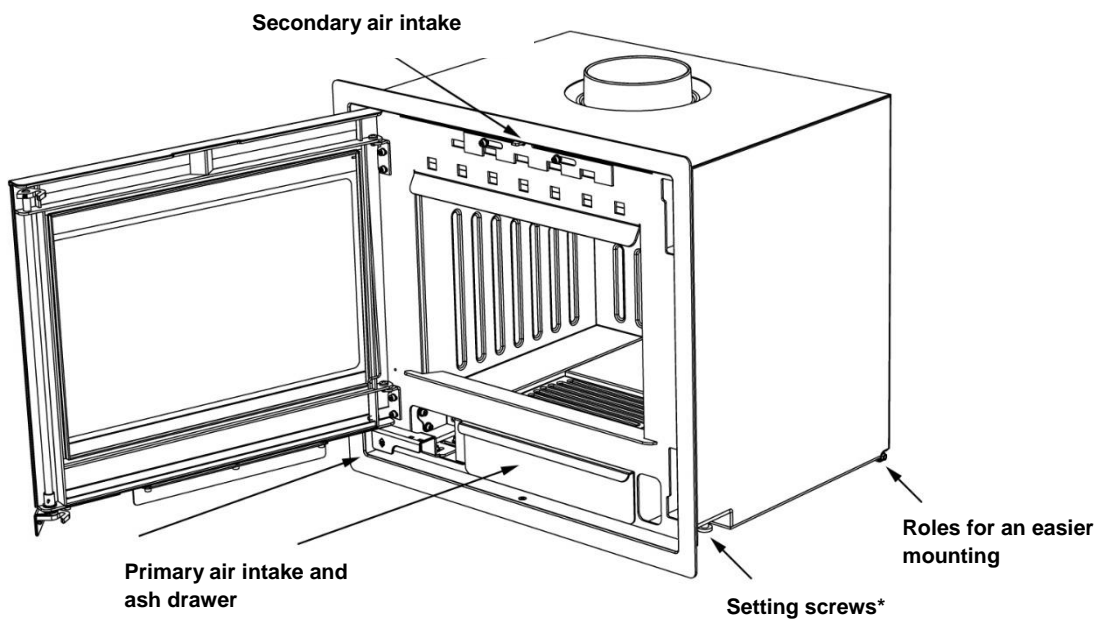

\*Remember to mount the set screws before the insert is placed at the correct position. The set screws are in the ash drawer.

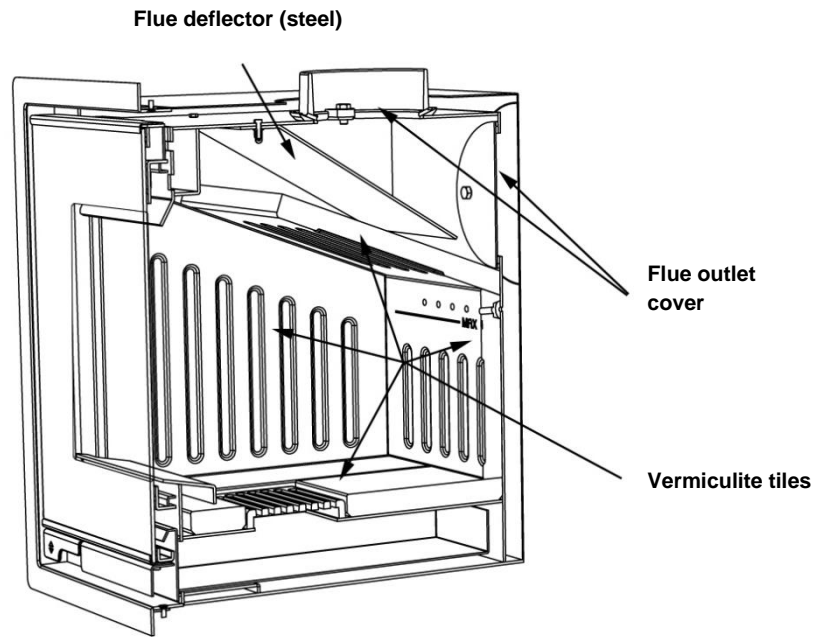

### Surrounding aperture

The insert is constructed in a way that makes it possible to make the brickwork shut almost tight around the insert the first 10 cm in the depth from the front. This means that the hole in the front brickwork must be 54-55 cm high and 58.5-59 cm wide. After the first 10 cm in the depth there must be 2.5 cm air space around the insert which gives a minimum total width of 63.5 cm. and a total depth of minimum 49 cm in the hole. It is very important to ensure the 2.5 cm air space around the insert and that the installation is correct, otherwise the fireplace insert will not cool down sufficiently. A correct cooling is crucial for the energy efficiency as well as for the function of the Aduro-tronic.

The front of the insert with the frame covers an area of 57.4 cm in height and 63.5 cm in width.

When making the whole in the brickwork then please also remember that you might need some extra space when the pipe has to be mounted.

## **2.1 Position of the stove / distance requirements**

The new fireplace insert must be installed in a suitable and physically possible position. You need to be sure that the position complies with local regulations. Distance requirements will only apply if the fireplace insert is to be placed close to flammable materials. See below:

<b>Distance to flammable material</b>			
Behind the fireplace insert	To the sides of the fireplace insert	To furniture	Minimum height above floor level
25 cm	30 cm	110 cm	26 cm

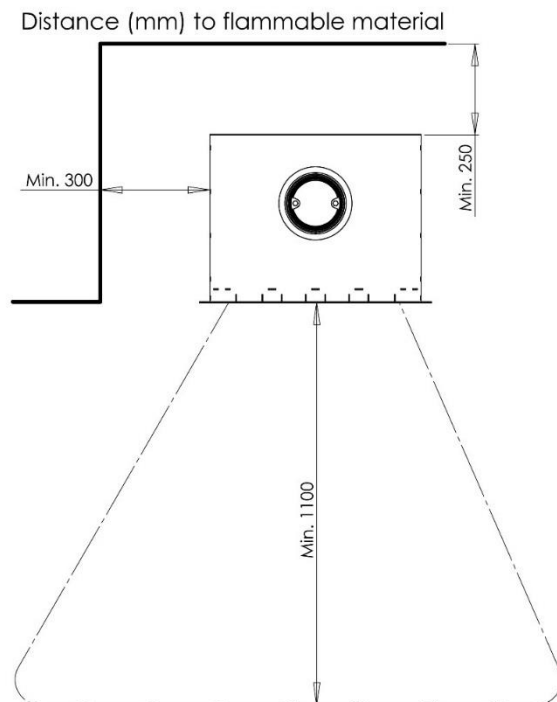

It is possible to reduce the distance to flammable material by insulating with at least 5.0 cm insulation with identical properties to Aduro Superisol, Isolrath 1000 or similar material around the Aduro 5.1. Please make very sure that there is still at least a 2.5 cm space around the Aduro 5.1. This means that the distance to flammable material can be reduced to 7.5 cm (2.5 cm space around the insert + 5 cm insulation):

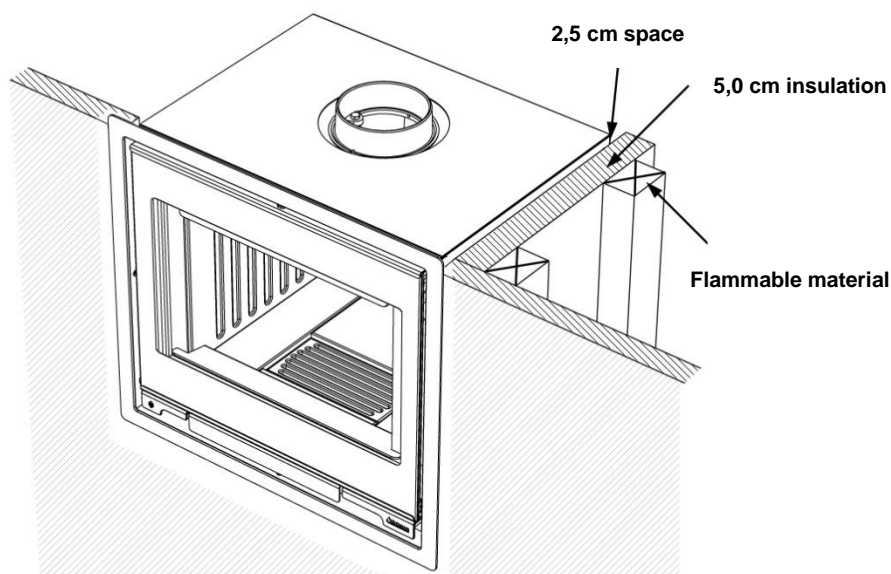

If the fireplace insert is to be placed close to flammable material such as a wooden floor or carpet, it must be placed on a non-flammable base. The floor plate should extend for at least 30 cm in front of the fireplace insert and 15 cm on each side measured from the opening of the combustion chamber.



**The fireplace insert must be installed on a floor with the adequate load-bearing capacity. If the existing construction does not meet this requirement, appropriate adaptation measures must be taken (e.g. a load-distributing plate).**

## 2.2 Convection and ventilation

---

The Aduro 5.1 is built as convection stove. This means that air from the room circulates between the inner stove and the outer covering. As a result, the heated air is distributed evenly throughout the room. In order to fully exploit the energy in the wood, however, the heat generated around the fireplace insert and the flue pipe (that connects the fireplace insert to the insulated chimney) should also be used. The calorific values depend on the length of the uninsulated flue pipe – initially, the first metre of uninsulated flue pipe will increase the efficiency by approx. 5 %. There should be at least 25 mm space around the fireplace insert. It is important that the space around the fireplace insert and the flue pipe is ventilated. There should be ventilation openings of at least 200 cm<sup>2</sup> both below and above the fireplace insert. There are many ways to create ventilation around the flue pipe. Some examples are given below.

## 2.3 Connecting the flue pipe

---

The fireplace insert can be connected using either flexible piping or regular flue piping. If you use flexible piping, you must ensure that the piping is designed for flue gas use, and can withstand high temperatures. Flexible piping may only be used in an existing fireplace installation. Therefore we recommend that you consult your chimney sweep before using flexible piping. You can use both the top and rear outlets on the fireplace insert, depending on what suits your installation best. The Aduro 5.1 is supplied ready for fitting the flue pipe on the top. If the flue pipe is to be fitted on the back, the round circle should be removed from the rear plate of the fireplace insert. The cover plate (that covers the rear outlet) should then be moved to the top outlet. A flue pipe with an internal diameter of 150 mm should be used for the Aduro 5.1.

It will usually be easier to use flexible piping if there is not particularly good access to the chimney. If, on the other hand, you have complete access, we recommend that you use a regular 2.0 mm steel flue pipe.

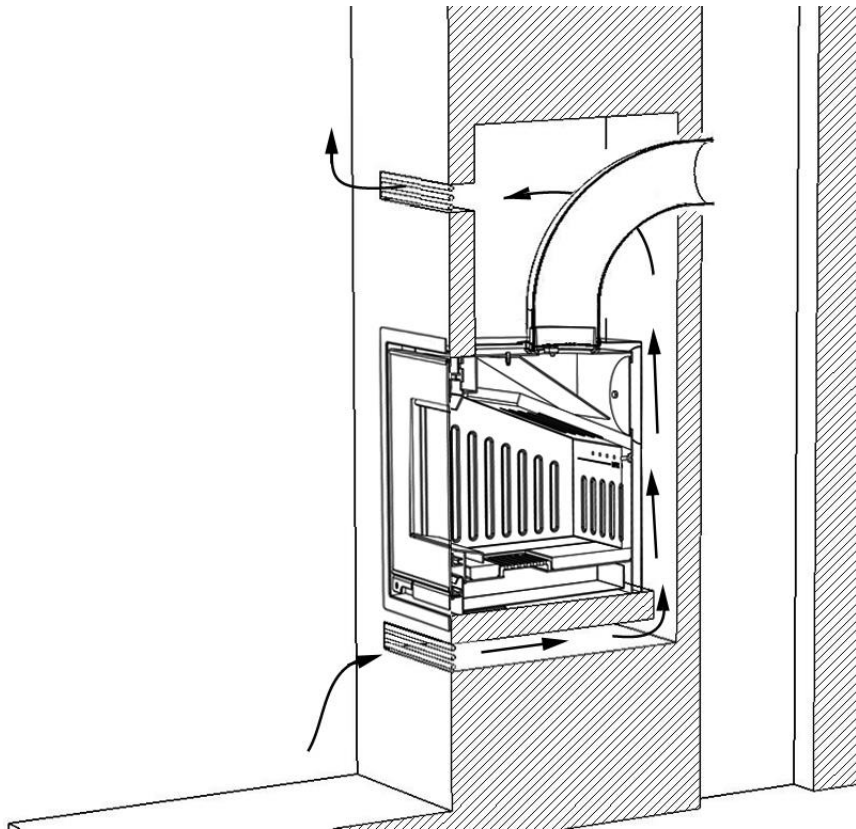

### **2.3.1 Flue piping in new installations**

---

The easiest way of installing the flue pipe is through a chimney with an aperture of 160 mm straight above the exhaust connector on the inset. In this case, a straight 2.0 mm flue pipe with an internal diameter of 150 mm of a suitable length should be used. 3 x gasket bands should be placed around the flue pipe, which is then pushed up into the chimney. The fireplace insert is placed in position and the flue pipe is pulled down over the exhaust connector.

The fireplace insert can also be fitted with a steel chimney. The steel chimney should be placed directly above the exhaust connector. We recommend the use of a steel chimney that is self-supporting and fitted with a telescopic flue pipe. This solution allows you to lift the flue pipe and remove the insert without affecting the chimney. Remember that the space above the fireplace insert should be sealed off with a horizontally positioned non-flammable plate. This plate should be installed at least 85 cm below the ceiling. The space under this plate (above the fireplace insert) should be ventilated as described on the previous page.

If the chimney goes directly down into the fireplace insert without sharp angles or significant bending, a wall sleeve will usually not be needed. It is also important that there is no edge inside the chimney where soot can collect.

### **2.3.2 Flue pipe installation in a large chimney**

---

A chimney that is larger than the flue pipe can be sealed with fixed rockwool batts, that are trimmed so that they adhere tightly around the flue pipe. The batts should be laid in 3 layers and spread with fireplace mortar before they are pushed up into the chimney from below. The fireplace mortar will stiffen and fix the batts to form a floor in the chimney.

### **2.3.3 If you do not have free access to the chimney and are using flexible piping**

---

The flexible piping should be trimmed to the appropriate length. Please note that the flexible piping should protrude approx. 10 cm into the pipe sleeve. Then a thin gasket should be placed between the flexible pipe and the pipe sleeve in the chimney and the flexible pipe should be pushed securely into place in the pipe sleeve. Adjust with the setting screws until it is in the correct horizontal position.

The fireplace insert can be connected to a chimney to which other heat sources are connected.



## 3. Lighting the stove

### Important safety information

- The fireplace insert will become warm during use and therefore it should be treated with all necessary caution.
- Never keep easily combustible fluids such as petrol in the vicinity of the fireplace insert.
- Never use easily combustible fluids to light the fire in the fireplace insert.
- When lighting a fire, it is important to get the fire burning fast. If the fire does not start quickly and wood only smoulders, it can cause strong smoke formation and in worst case cause an explosive ignition of the flue gasses, which can damage the stove.
- Never empty the ashpan when the fireplace insert is warm. Embers may still be found in the ashpan for up to 24 hours after the fire has gone out. Please wait to empty the ashpan until you are sure that there are no embers in the ash.
- The door should be kept closed while the fireplace insert is in use. While lighting the fire, the door can stand ajar for the first few minutes.
- In the event of a chimney fire: Close all the dampers on the fireplace insert and call the fire-fighting service.

### 3.1 Damper

---

The stove is equipped with different dampers, which regulates the combustion air: primary, secondary, and tertiary air supply. The primary air is used at the beginning to get the fire going, the secondary air keeps the fire burning evenly, and the tertiary air ensures that flue gasses are burned. You must always add secondary and tertiary air, while firing the stove.

#### 3.1.1 Secondary damper

---

The secondary damper above the door should always be open while the fireplace insert is in use. This damper allows you to adjust the fireplace insert to the chimney draft and the heat output you require. Turning the damper to the left decreases the air supply and turning to the right increases the air supply. In normal circumstances, the fireplace insert should be working with this damper open between 60 % and 100 %. You should never close the air intake so far that the flames are extinguished. There should always be visible flames in order to achieve clean and efficient combustion. A too low supply of air can lead to bad combustion, high emissions and a bad efficiency. The air-wash system, that minimizes soot collecting on the front glass pane, is also adjusted by this damper.

If you want to fire the stove with the lowest effect possible – around 3 kW – you must close the secondary damper almost completely 45 minutes after the wood has been put in. At this point there are only few flames and the stove can burn clean by using the tertiary air from behind in the stove.

**Aduro Key:** The stove comes with an Aduro-key which provides easier control of the secondary damper. The key is fitted onto the control handle in order to easily adjust the airflow from side to side.

#### 3.1.2 Primary damper

---

When you add a new log, the primary damper should be opened until the fire is burning properly. In order to utilize the fuel to the fullest extent, the embers should have burnt for so long that it is necessary to open the primary damper for approx. 2 minutes to get the new log to burn.

In order to reduce the risk of ash falling from the stove when the door is opened to add more fuel, it is a good idea to open the primary damper for approx. 1 minute before the door is opened. This increases the draft through the stove and reduces the risk that ash will drop on the floor.



**If you overload the fireplace insert and burn more than approx. 3.4 kg wood/hour, there is a risk that the lacquered surface of the stove will become discoloured and eventually fall off. The stove can be resurfaced, but this is not covered by the manufacturer's guarantee. In the same way, any other damage to the stove caused by overloading will not be covered by the guarantee.**

## 3.2 Aduro-tronic

The patent-applied control Aduro-tronic is a manually operated mechanical start-up device, which works without the use of electricity and automatically regulates the combustion. All you have to do is put dry wood in the stove and activate the control system. Aduro-tronic does the rest, leaving you to enjoy the flames, the benefits of efficient combustion, and a reduced firewood usage up to 40 %. For further information, go to [www.adurofire.com](http://www.adurofire.com).



### 3.2.1 How to operate Aduro-tronic

#### When lighting

When lighting a fire in the stove for the first time, the maximum amount of primary air will be needed to light the fire. For that reason, the primary damper can be kept "forcibly open". This is done by pulling the primary damper forward as far as possible and then fixing it with the Aduro Key (see illustration). When the stove is warm and a layer of embers has been created on the bottom of the combustion chamber, the Aduro-tronic can be set to the automatic position, i.e. the Aduro Key can be removed. Alternatively, you can leave the door ajar the first minutes during lighting the fire (without the key).

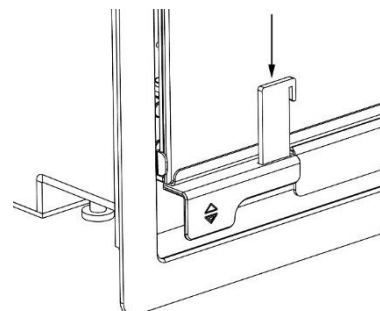

#### When stoking

Each time fresh wood is put in the stove, a precise amount of primary air will be allowed in for the first few minutes. What's more important is that the primary air is not allowed in for too long. This is to ensure optimum combustion. The Aduro-tronic control will ensure intake of primary air at the right tempo. The automatic is activated by pulling the primary damper out each time fresh wood is put in the stove. The automatic closes then the primary air gradually.

#### Regulation of the Aduro-tronic control

The control is pre-set to close the primary air intake within 6 minutes. This setting has been used during testing at the Danish Technological Institute using a standard chimney and 'standard' sized logs (approx. 30 cm long, 10x10 cm thick) with maximum moisture content of 18%. In practice, such circumstances can differ, which is why the Aduro-tronic control can be adjusted to your circumstances. If you want a slower intake of primary air (e.g. for a slower flue draft, larger sized wood or for longer intervals between stoking), adjust the

screw on the front of the control level using a small allen key to slow closure rate. If the screw is turned to the right, closing time is increased and if turned to the left, closing time is reduced.

### 3.3 Ventilation / fresh air supply

---

In order for the fireplace insert to function at optimum efficiency, air is needed for the combustion process. There must be sufficient fresh air coming into the room containing the fireplace insert. In very well-insulated houses, or houses with powerful cooker hoods and/or air conditioning systems, a vacuum can be created around the fireplace insert, leading to smoke leakage and poor combustion. In these circumstances, it might be necessary to open a window to provide air for combustion and to equalize the vacuum. Alternatively, you could fit an air vent in the room containing the fireplace insert. The amount of air needed for combustion is 25 m<sup>3</sup>/h.

### 3.4 How should I use my fireplace insert?

---

The fireplace insert is intended for *intermittent* combustion. This means that each stoking should burn down to embers before new logs are added.

To obtain the best possible combustion, you should regulate the effect/heat output with the fuel. Burning small logs provides more powerful combustion than burning large logs as the surface area is greater and more gas is released. The amount of wood in the combustion chamber is another factor that affects combustion. The optimum combustion is achieved by placing two logs in the stove. If you want an enhanced effect, you can add more logs. The ideal heat output is reached by burning approx. 2.2 kg per hour.

If you experience problems lighting the fire or the fire dies after a short time, it can be due to the following reasons:

- The fire wood is not dry enough. The fire wood should have a moisture content of max. 18%.
- There is a negative pressure in the house. See section 3.3.
- The smoke outlet from the outside may be blocked from soot. This can occur after chimney sweeping. Control the smoke outlet.
- The used amount of wood may have been too small. Therefore, the embers were too weak and cold to light the next load of wood.



**Use of dry wood of the right size is important to achieve optimum combustion.**

### 3.5 The first time a fire is lit

---

The fireplace insert is packed in recycling packaging. The wood from the packaging can be sawed into smaller pieces and used the first few times a fire is lit. The plastic packaging must be disposed according to national rules regarding disposal of waste.

The first few times the fireplace insert is used, there may be some smoke and unpleasant odours from the fireplace insert, which is fairly normal. This is caused by the heat-resistant paint hardening. Make sure there is sufficient ventilation during this stage. It is also important not to let the fire burn too fiercely the first 2-3 times, so that the fireplace insert has time to expand slowly.

You should also be aware that the stove may make some clicking sounds as it heats up and cools down – like pouring boiling water into a sink. These are caused by the great differences in temperature to which the materials are being exposed.



**During the first firing, which should be carried out using approximately 1 kg of wood, the stoking door must be left slightly open and must not be closed until the stove is cold. This is to prevent the sealing rope sticking to the stove.**

### 3.6 Lighting a fire in the fireplace insert

---

The fire lighting method is very important for starting combustion quickly and efficiently.

1. Open the primary damper under the door and the secondary damper behind the door. The illustration below shows the stove seen from the front with the dampers indicated.
2. Place a log of wood crosswise in the combustion chamber and put 2 firelighters close to the log. Light the firelighters and quickly put a new log close to the firelighters and several small logs at an angle above it. Air must be able to reach the firelighters, but the logs should be touching to “warm” each other.
3. Keep the door approx. 1 cm ajar, until the glass is too hot to touch. Then close the door. When there are distinct, visible flames and the fire has taken hold, close the primary air intake/damper



**The control handles will get warm when the fireplace insert is in use. Please use the glove provided when you operate the fireplace insert.**

### 3.7 Recommended fuels

---

Wood and wood briquettes. We recommend the use of split hardwood that has been stored outdoors under cover for at least 1 year. Wood that has been stored indoors has a tendency to become too dry and will burn too quickly. We recommend that you fell the wood during the winter when a lot of the moisture in the wood will have been drawn down into the roots. In order to achieve optimum combustion, the wood's moisture level should not exceed 18 %, which roughly corresponds to storing the wood under cover outdoors for one year. The moisture level of the wood can be measured using a moisture meter or by applying dishwashing liquid to one end of the log and blowing air in the other end. If the wood is dry enough, soap bubbles will appear. The wood should be chopped into logs with a diameter of approx. 10 cm and a log length of max. 40 cm. Firing with wet fuel will reduce the energy efficiency and increase the particle emission.

Burning varnished wood, impregnated wood, chipboard, paper, and other waste is strictly forbidden. Burning these materials will damage the environment, the fireplace insert, and your own health. Fossil fuels must not be used.

## 4. The chimney

The optimum combustion is achieved at a constant chimney draft of 10-14 Pascal (Pa) measured in the flue pipe above the stove (when having a smoke exhauster). However, with natural draft (chimney without smoke

exhauster) the draft in the chimney will be between 18-25 Pa when conditions are optimum. There are many factors that affect the chimney draft, including the outside temperature, wind strength, and surrounding buildings. There are no requirements with respect to specific chimney heights, but a chimney must be tall enough to provide a good draft. If the recommended chimney draft is not achieved, there may be problems with smoke out of the door by firing.

Data for chimney calculation	Wood
Flue temperature at [20°C]	266
Chimney draft at testing power [mbar]/[Pa]	0.12 / 12
Flue gas mass flow [g/s]	7.5

#### 4.1 Inadequate draft in the chimney

---

If you experience poor draft in the stove after the installation, please make sure that there is nothing in the chimney to restrict the smoke and that no nearby buildings or trees affect the winds around the chimney.

If the chimney is too short, leaks, or is inadequately insulated, there may be problems with the chimney draft (let the chimney sweep assess this). The draft should be sufficient during the ignition phase when the stove/chimney is cold to provide a clean combustion and prevent smoke leakage. Therefore, we recommend a chimney draft around 5 Pa in the ignition phase.

Once the ignition is a success and the smoke temperature is rising, it is important that the chimney draft reaches a stable area around 18-25 Pa in operation (1 hour after ignition) when the chimney/stove is hot. The draft in the area of 18-25 Pa when the stove is hot is essential in order to achieve an optimum and clean combustion. Therefore, we recommend that you measure your chimney draft when the chimney is cold and when it is hot after 1 hour in operation.

In practice, the chimney draft will differ – especially in cold condition. Therefore, the best indication of the chimney draft is to measure the draft when it is hot. If the chimney sweep judges the draft to be sufficient, but you still have problems lighting a fire, try extending the fire lighting phase by using more thin pieces of kindling and 1-2 firelighters, so that the chimney gets thoroughly warm. The chimney will not draw at optimum effect until it is warm. When a layer of embers has been formed, add 2-3 dry logs.

If it is impossible to establish a sufficiently natural chimney draft, the chimney can be fitted with a smoke exhauster, e.g. Aduro DraftOptimizer.

#### 4.2 Chimney and Smoke

---

If you experience smoke coming out of the stove or the start section of the smoke pipe, it could be due to certain weather conditions. On stormy or cold winter days or if the chimney has not been used in a while, a cold plug can be created in the chimney, meaning the natural draft will be at its minimum.

If the chimney is cold and cold plugs are created, you may experience smoke leaks during the ignition and startup phase. In this situation there can be more smoke than usually in the combustion chamber and some of it might leak out of the stove. Therefore, if you have a cold chimney that has not been used for a while, we recommend that you use some wood sticks to heat the chimney and eliminate the cold plug.

## 5. Maintenance and cleaning of the stove



All maintenance and cleaning of the stove should be carried out when it is cold.

### Combustion chamber

The fireproof tiles in the combustion chamber eventually wear out and should be replaced when the cracks are more than 0.5 cm. The durability of the tiles depends on how often and how intensively the stove is used. You can change the tiles yourself. They are available as a ready-to-use set. For further information, go to [www.aduroshop.com](http://www.aduroshop.com).

### Glass

Wet wood, unsatisfactory chimney draft, and wrong use of the stove can leave soot stains on the glass pane. They can easily be removed using a damp cloth that you dip in cold ash and rub on the sooty glass. Special cleaning agents are also available to remove soot from glass, e.g. the Aduro Easy Clean pad. The pad neither scratch nor damage the glass and is for multiple usage. Water or other cleaning agents are not necessary.

It is common maintenance to tighten the glass fittings shortly after the stove has been installed as well as to check if the gaskets are properly placed.

### Gaskets

With time, gaskets around glass and door will wear. We recommend that you inspect them regularly. If leakages appear, they must be replaced.

### Ashes

Empty the ashpan before it gets completely full. Always leave a layer of ashes in the stove because it insulates and makes it easier to light a fire.

### Cleaning the stove

The stove's surface is treated with a heat-resistant Senotherm® paint, which will stay at its best just by being vacuumed with a small, soft mouthpiece or dusted with a soft, dry cloth. Do not use spirit or other solvents, as they will remove the paint.



Do not clean the stove with water. If the stove is exposed to moisture, the stove may develop rust.

The inside of the stove and the flue pipe can be cleaned through the door or alternatively through the cleaning aperture in the flue pipe/chimney. The upper fireproof tile (the baffle plate) can be removed. To allow free access to the top of the stove and the flue pipe, remove the baffle plate in steel. The flue pipe can

be removed from the stove and cleaned. Cleaning of the inside of the stove and the flue pipe should be undertaken at least once a year, or more frequently if necessary, depending on how often the stove is used. This work can also be carried out by the chimney sweep or your local Aduro GO partner.

### **Repairing the surface**

Aduro stoves are painted with a heat-resistant paint that can withstand temperatures up to 500 degrees. If the surface of the stove gets scratched or worn, it can easily be renewed using this type of paint. Everybody can repair the surface and obtain a perfect result. The paint is available in black metallic from your local dealer or at [www.aduroshop.com](http://www.aduroshop.com).

### **Spare parts and unauthorized alterations**

You may only use original spare parts for your stove. All forms of unauthorized alterations to the stove are strictly forbidden, as the stove will no longer comply with the approved specifications. At [www.aduroshop.com](http://www.aduroshop.com) you can buy original spare parts for your stove.

## **6. Accessories**

For Aduro stoves we offer a wide product range of accessories to fulfil the experience: Companion sets, firewood baskets and buckets, fireplace grid, briquette buckets, floor hearths in glass and steel, flue pipes, Aduro Easy Firelighter, and Aduro Easy Clean pad. For further information, go to [www.adurofire.com/accessories](http://www.adurofire.com/accessories).

## **7. Right of complaint**

In accordance with the Danish Sale of Goods Act, you have a two-year right of complaint from the date of purchase of the fireplace insert. The dated receipt will be sufficient proof. The right of complaint does not cover damages caused by faulty installation and use of the stove. The right of complaint also does not cover loose and wearing parts (glass, gaskets, firebricks, handles, slides, painted surfaces, cast iron grate etc.) as they are subject to wear during normal use. These parts can be bought as spare parts in our webshop [www.aduroshop.com](http://www.aduroshop.com).

In addition, the right of complaint does not cover:

- Damages resulting from incorrect installation and use of the stove, e.g. overheating and wrong or missing maintenance of the stove.
- Damages caused by (condensation) water in and around the chimney, too much or too little draft in the chimney and missing maintenance/cleaning.
- Mounting or demounting relating to repairs.
- Transportation costs relating to repairs.
- Damages to the stove caused by external influences or damages caused by the stove on other objects.