

GOZNEY°
EU DOC-0488-01

S1

Stone

Live-Fire cooking made easy.

Introduction



DANGER

If you smell gas:

Shut gas off to the appliance.

Extinguish any open flame.

If odour continues, keep away from the appliance and immediately call your fire department.



WARNING

Do not store or use gasoline or other flammable liquids or vapors in the vicinity of this or any other appliance.

An LPG cylinder not connected for use shall not be stored in the vicinity of this or any other appliance.

This instruction manual contains important information necessary for the proper assembly and safe use of the appliance.

Read and follow all warnings and instructions before assembling and using the appliance. Follow all warnings and instructions when using the appliance. Keep this manual for future reference.

Never operate this appliance in enclosed areas. Failure to follow these instructions could result in fire or explosion which could cause property damage, personal injury or death.

—
Never operate this appliance unattended.

—
Never operate this appliance within 1.5m of any structure, combustible material or other gas cylinder.

—
Never operate this appliance within 7.5m of any flammable liquid.

Do not fill the cooking vessel beyond the limitation of the door dimensions.

—
Heated liquids remain at scalding temperatures long after cooking process. Never touch cooking appliance until liquids have cooled to 45°C or less.

—
If a fire should occur, keep away from the appliance and immediately call your fire department. Do not attempt to extinguish an oil or a grease fire with water.

Contents

GENERAL ADVICE	8
PARTIAL ENCLOSURES	9
PRODUCT OVERVIEW	10
DATA PLATE	12
1 OPERATION & INSTALLATION	15
SAFETY CONSIDERATIONS	16
FIRE	17
CARBON MONOXIDE	17
2 SETUP & ACCESSORIES	19
ADJUSTING THE STONES	20
MOVING THE OVEN	21
OVEN PLACEMENT	22
FLUE ASSEMBLY	24
DIGITAL TEMPERATURE DISPLAY SET UP	25
DIGITAL TEMPERATURE DISPLAY	26
TROUBLESHOOTING	27
E1 ERROR CODE	27
E3 ERROR CODE	27
OPTIONAL ACCESSORIES	28
ROPE SEALED DOOR	28
FLUE EXTENSION	28
DOME S1 MANTLE	29
NEAPOLITAN ARCH	29
3 FIRING UP GAS	31
CONNECTING TO GAS	32
GAS SAFETY	33
INDOOR USE	35
INSTALLING THE IGNITER BATTERY	36
CONNECTING THE GAS HOSE	38
PUSH FIT REGULATOR	39
CLOCKWISE/ANTICLOCKWISE REGULATOR	39
TESTING FOR LEAKS	40
IGNITION	41

FIRST FIRING	42
TROUBLESHOOTING GAS BURNER	43
DISCONNECTING GAS	44
PUSH FIT REGULATOR	44
CLOCKWISE/ANTICLOCKWISE REGULATOR	45
4 GENERAL MAINTENANCE	47
MAINTENANCE	48
CLEANING THE VENTURI	48
CLEANING THE OVEN	49
INTERNAL	49
EXTERNAL	50
REPLACING THE PROBE	51

GENERAL ADVICE

Dome S1 gets extremely hot and should not be used by children. Do not allow children near the device during or after operation. Dome S1 can stay hot for a few hours after use.

Do not use under any apartment or balcony or deck.

This appliance is for cooking purposes only. It must not be used for other purposes, for example heating a room.

Dome S1 has not been designed or intended to be used on a boat or within a recreational vehicle or any other form of confined area.

Assembly and operation of the oven should be carried out by a competent person.

The use of alcohol, prescription or non-prescription drugs may impair the consumers ability to assemble or operate the device safely.

Do not use any plastic or glass utensils within Dome S1.

Use heat-resistant gloves when operating the oven.

Do not insert items into Dome S1 that are bigger than the dimensions of the oven mouth.

Do not over fill Dome S1 or cover the burner.

Do not move Dome S1 whilst in operation.

Do not operate Dome S1 in strong winds. Winds can extinguish the flame and also cause irregular air pressure resulting in the flame and heat coming out the back of Dome S1. Use a wind break in open areas but keeping over 45cm away from the device.

Do not pour water on to the cooking stone as this will likely crack it and could be dangerous because of oil and grease.

Do not wear loose flammable clothing or sleeves near Dome S1.

Parts sealed by the manufacturer or the agent shall not be manipulated by the user.

Never use wood.

For replacement parts go to Gozney.com.

EU DECLARATION OF CONFORMITY

Manufacturer's Name: Gozney Limited
Manufacturer's Address: Units 18 & 19,
Radar way, Christchurch, Dorset, BH23
4FL UK.

Herewith declare that this product
Product: Dome S1 oven
Model(s) / Type(s): 4555-S1-01
Trade name: Dome S1

Is in conformity with the following EC
directives:

- Gas Appliance Regulation (EU)
2016/426
- Gas Appliances (Enforcement) and
Miscellaneous Amendments Regulations
2018 (UK Statutory Instrument 2018 No.
389)

and that the following harmonized
standards have been applied:
EN 498:2012[E]

END OF LIFE

At product's end of life, please dispose
responsibly.

Product Overview - What's in the Box

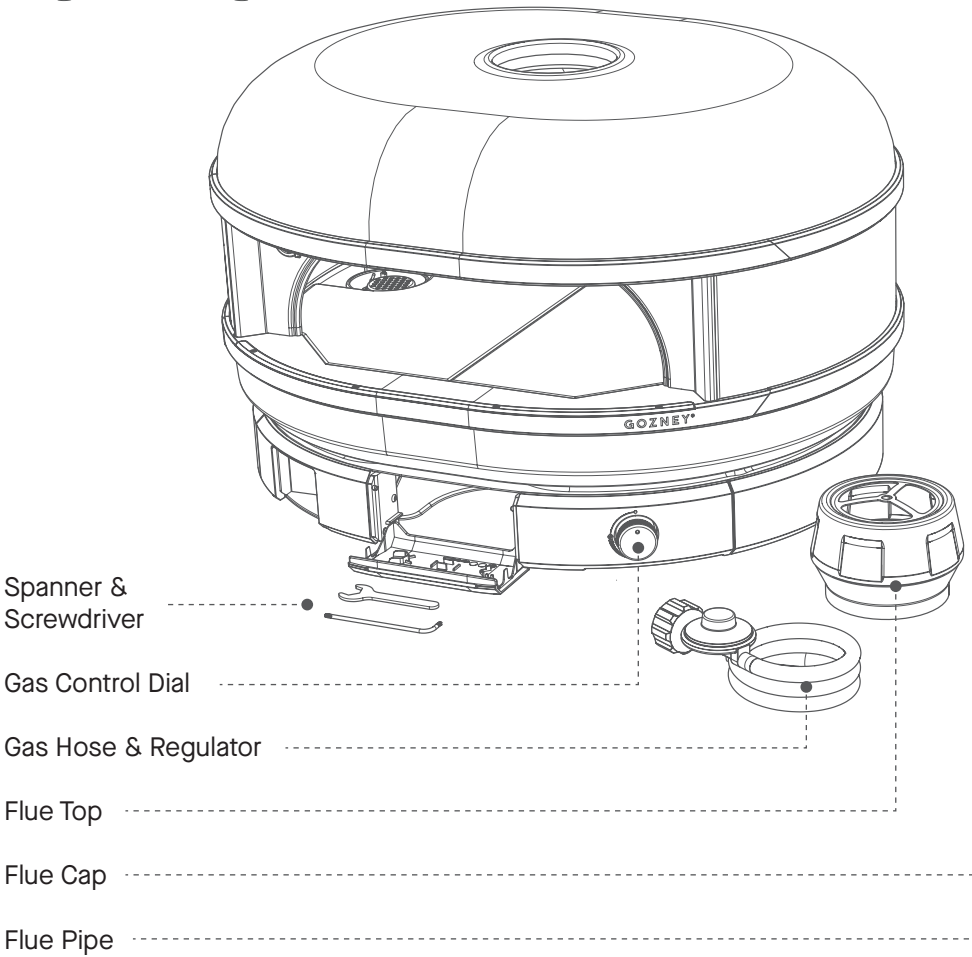
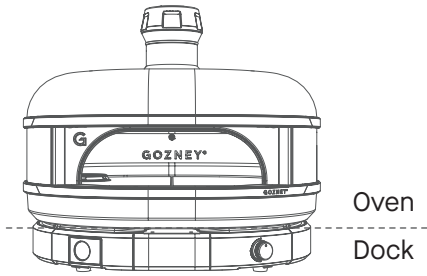

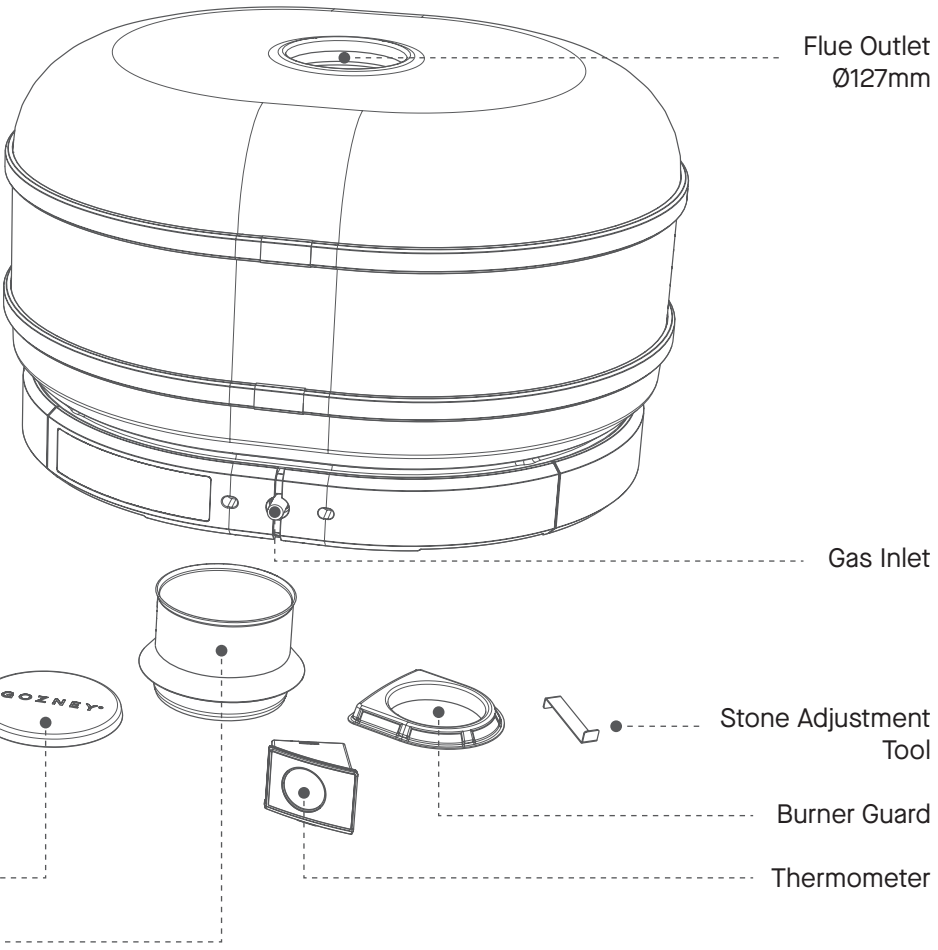

Flue Outlet
Ø127mm

Gas Inlet

Stone Adjustment
Tool

Burner Guard

Thermometer

Data Plate

Gozney Limited, Units 18 & 19, Radar Way, Christchurch, Dorset, BH23 4FL UK.	
Appliance Name:	Gozney Dome S1
Model/Type No.:	4555-S1-01
Trade name:	Gozney Dome S1
Total nominal heat output for the gas burner:	<p>8.2 kW (592g/h) for $I_{3B/P(30,50)}$ $I_{3P(30,50)}$</p> <p>8.2 kW (614g/h) for $I_{3+(28-30/37)}$ $I_{3B/P(37)}$ $I_{3P(37)}$</p> <p>8.2 kW (0.55l/h) for $I_{2H\ 12E+}$ $I_{2E\ 12EK}$</p>

Suitable for outdoor use.



Read the instructions before installing and using the appliance.

This appliance is for outdoor use only.

This appliance must be installed according to the regulations in force.

WARNING: accessible parts may be very hot. Keep young children away.

Pin Code: XXXX/XX/XXXXX



Injector Size	1.4mm		1.52mm	1.3mm
Gas Category	I _{3+(28-30/37)} I _{3P(37)}		I _{3B/P(30)}	I _{3B/P(50)}
Gas Type	Butane	Propane	Butane, Propane or their mixtures	Butane, Propane or their mixtures
Gas Pressure	28-30 mbar	37 mbar	30 mbar	50 mbar
Destination Countries	BE, CH, CY, CZ, ES, FR, GB, GR, HR, IE, IT, LT, LV, LU, NL, PT, SK, SI		AL, BE, BG, CY, HR, DK, EE, FI, FR, HU, IS, IT, LT, LU, MT, MK, NL, NO, RO, SK, SI, SE, TR	AT, CH, DE, SK

This section details the correct operation and install of a Gozney Dome S1.



Operation & Installation

SAFETY CONSIDERATIONS

This appliance must be installed on a secure level base prior to use.

WARNING: This appliance will become very hot, do not move it during operation.

WARNING: Keep away from children and pets.

The Dome S1 unit and the burner must always be well ventilated.

Do not move or leave Dome S1 unattended whilst in use.

Do not operate Dome S1 in strong winds. Wind can extinguish flame.

Do not burn wood in this oven.

The oven can become very hot. Do not

use the accessory hatch when the oven is in operation.

Do not wear flammable loose garments or sleeves.

Do not cover oven mouth when there is an active flame, this will cause damage to the oven.

This oven is not intended to be installed in or on recreational vehicles.

Product may contain sharp edges! Please use caution.

WARNING: Contact your local municipality for any building codes applicable to the use, installation and operation of outdoor barbecue appliances.

CARBON MONOXIDE

Carbon Monoxide is a highly poisonous gas which can be produced when the device isn't receiving enough ventilation.

We therefore recommend using gas fuel in a well ventilated area away from direct wind and to never cover the oven mouth when there is an open flame present.

It is difficult to know if your device is producing Carbon Monoxide as it is an odourless and colourless gas.

It can, however cause these symptoms when you are exposed to it:

- Tightness across the forehead
- Headache
- Weakness
- Dizziness
- Nausea
- Vomiting
- Coma, intermittent convulsions
- Depressed heart action, slowed respiration

If the exposure has been severe it may cause death.

Please follow local regulations and install a CO alarm if necessary.

FIRE

Most fires are caused by a build up of grease, or (if using gas) an improper gas connection. In the event of a fire ensure all people and pets are kept as far away as possible.

Use a fire extinguisher if possible, but if water is the only fire retardant available, thoroughly soak the area around the appliance. When spraying water on Dome S1 itself, do not use a strong jet of water, as this may cause splashing of burning grease, resulting in a further spreading of the fire.

This section details the set up of the oven and the accessories included with your Dome S1.

2

Setup & Accessories

Adjusting The Stones

Before using Dome S1 it is important that the four blue stone retention wedges and other packaging inside of the oven are removed.

The removable stone design of the Dome S1 means that they are not fixed inside the oven and as such can shift backwards during transport. If there is a large visible gap at the front of the stones, you can use the included stone adjustment tool to hook the back of the stone and pull it forward.

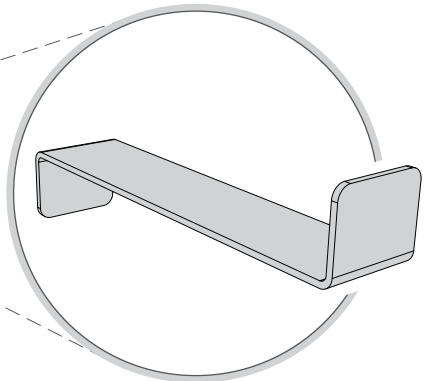
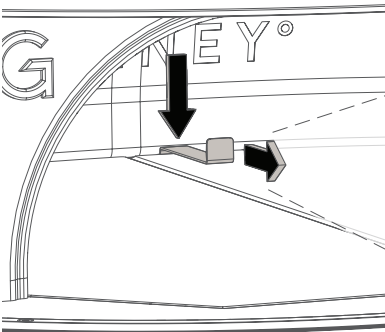
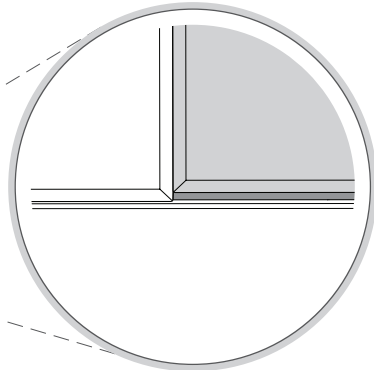
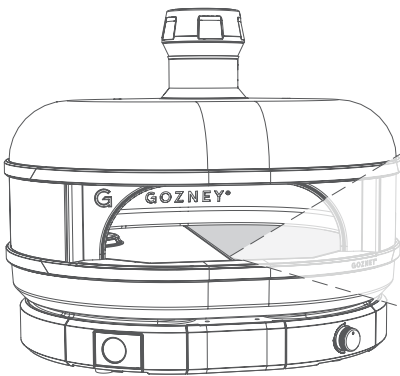

Moving the Oven

The lifting straps located on the bottom of the oven are only suitable for single use. Please remove them once the oven is located to its final location and use hand holds below.

Do not move Dome S1 whilst in operation or when it is still hot.

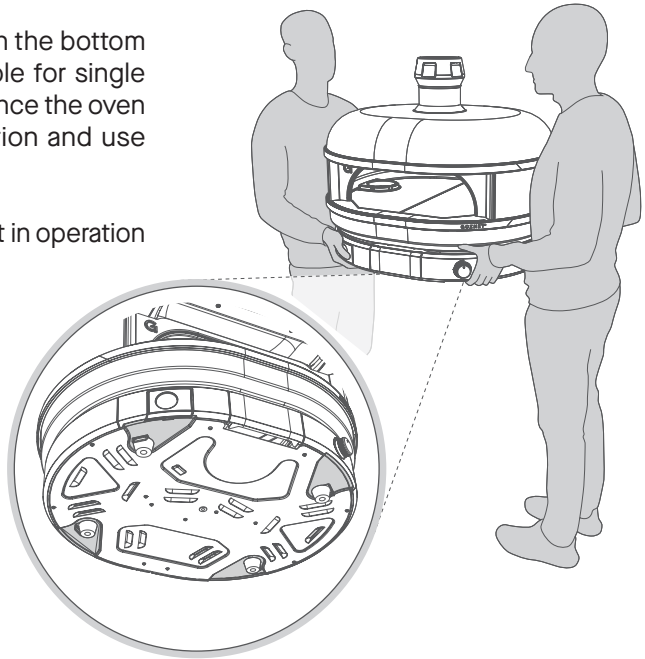

Never attempt to move the oven on your own. Two people should pick up the oven lifting from under the rounded ends of the oven, do not use the mouth of the oven as a lifting point.

Remove anything loose and all transit packaging in the oven before moving.

Always plan the route you are going to take, remove any obstacles on your path and ensure the oven will fit through the intended route.

Ensure the area you are moving the oven to fits with the guidelines on the following page.

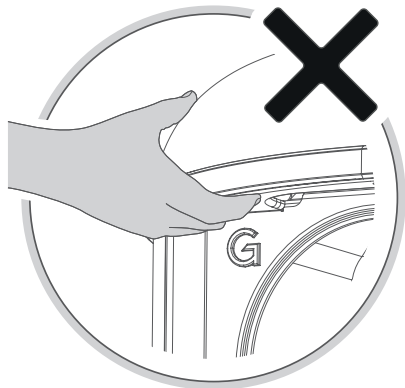

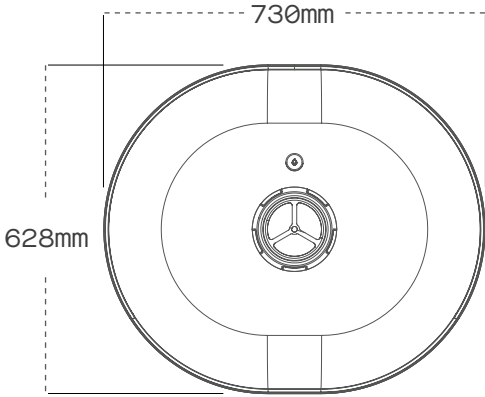

OVEN PLACEMENT

When deciding where to place Dome S1 ensure the area is large enough to accommodate the oven with 5cm around the base of the dock for air intake.

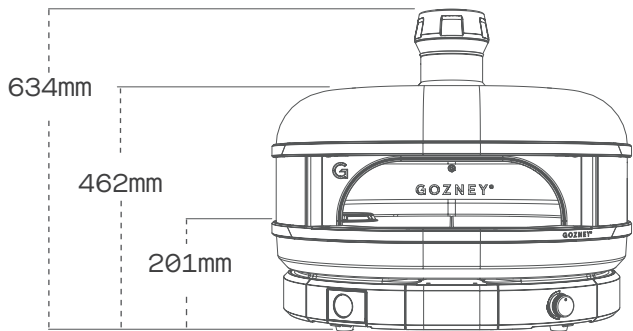

WARNING

When placing your oven it is important to maintain proper clearances from combustible construction. Ensure Dome S1 has 30cm clearance (back and sides) and 100cm clearance (front) from any combustible construction.

Always keep the area around the oven clear of any combustible materials, gasoline and other flammable vapours and liquids.

Under no circumstances is the oven to be placed under or on top of any combustible structure.

We recommend the height of the floor to be around the level of the bottom of the users elbow (usually around 120cm from the ground)

Ensure the surface the oven is being placed on is completely level, stable and capable of easily holding the weight of the oven - 60kg.



WARNING

Never operate the oven in high winds or if the wind is blowing into the oven mouth.

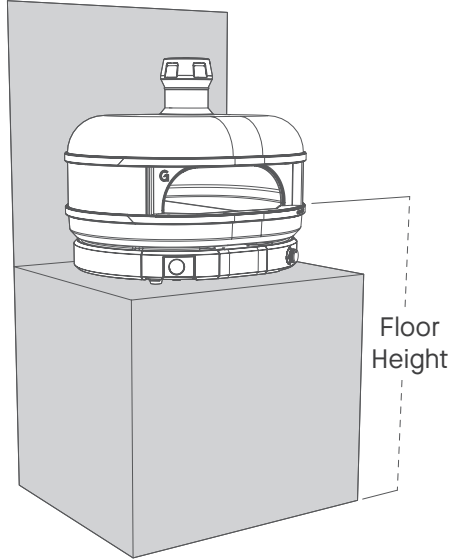

Wind should be taken into consideration when choosing a location. The oven should be orientated so that the mouth is facing away from the wind. Avoid using the oven in windy conditions, it is important to have wind breaks situated around the oven to stop the wind from blowing the flame down into the dock. If you see fire coming from the dock. Turn the oven off from either the gas bottle or control knob. Never operate the oven in high winds.

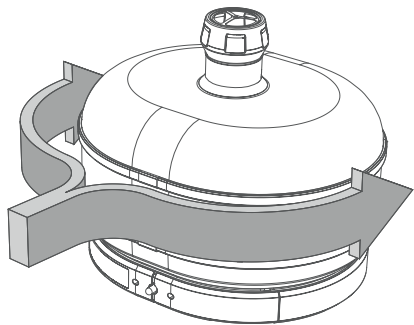

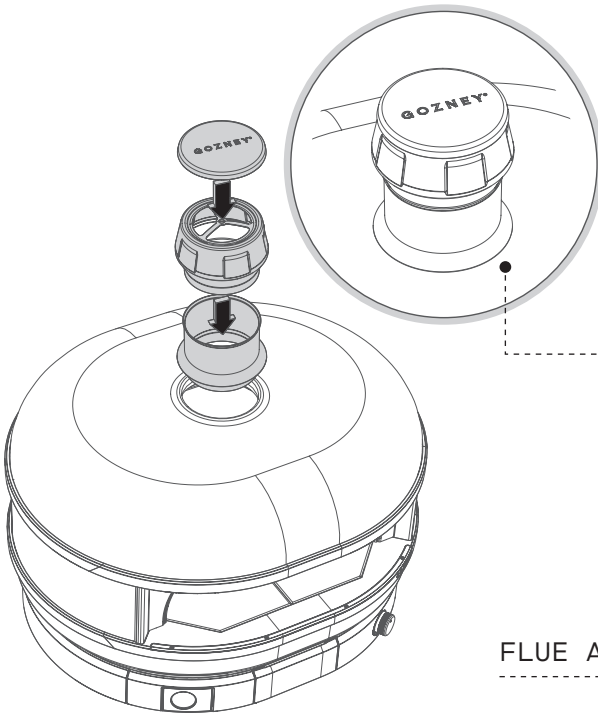

The flue is designed to have a rain guard which has a 5mm gap from the Dome S1.

FLUE ASSEMBLY

The rain cap prevents moisture from getting into the oven and should only be used when the oven is cooled and not in use. Ensure rain cap is removed before using appliance.

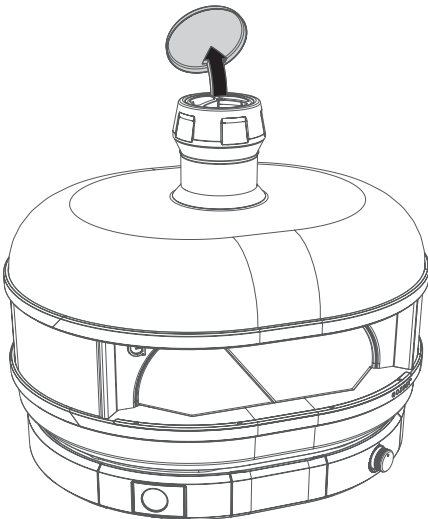

WARNING

Never leave the flue cap on when the oven is in use.

Digital Temperature Display

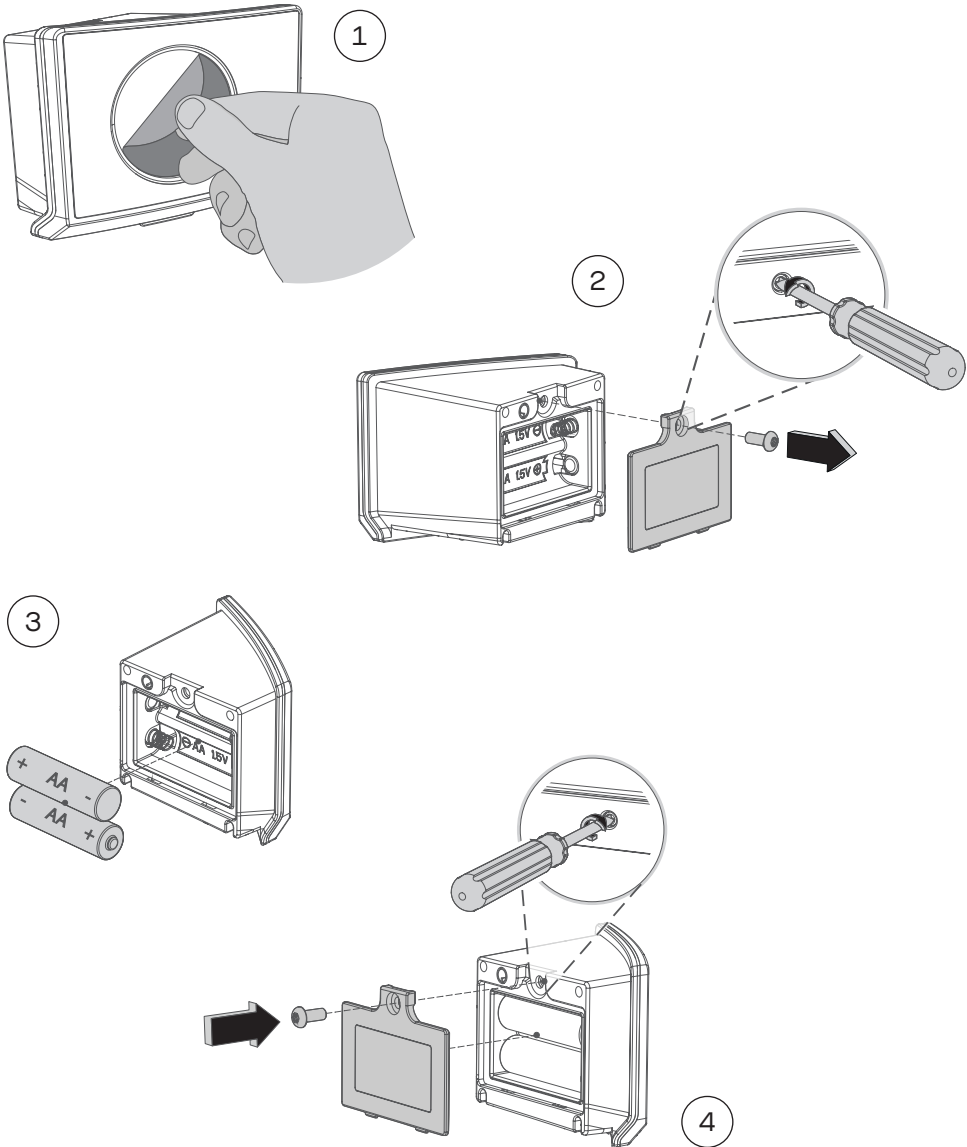

SET UP

After installing the batteries hold the power button down until the display turns on. Find the sensors jack by removing the plastic cap and plug into the rear of the display, the screen will then show the temperature from within the oven.

The Digital Temperature Display is held in place by magnets.

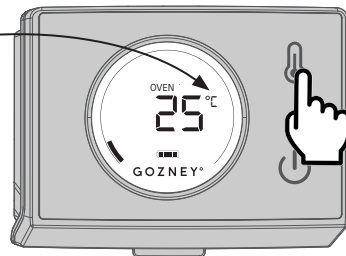
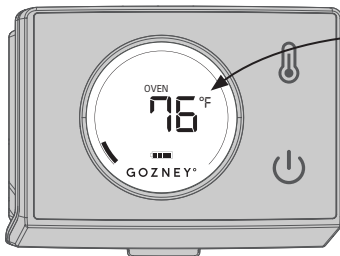
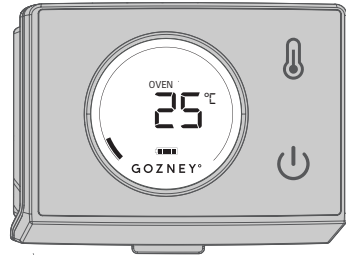
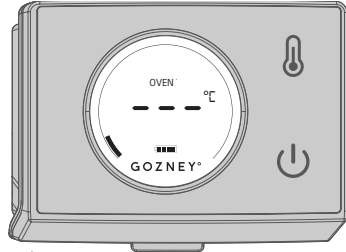
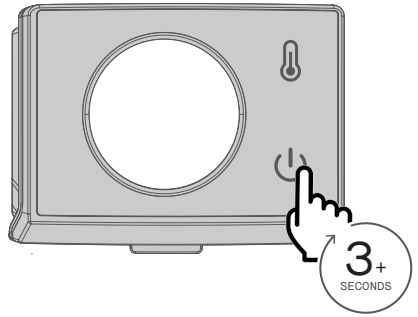
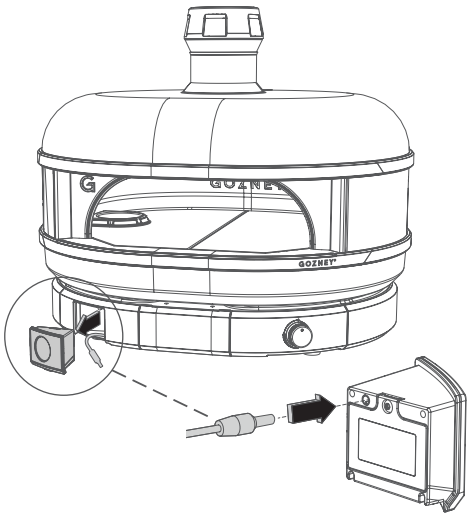

Digital Temperature Display Troubleshooting

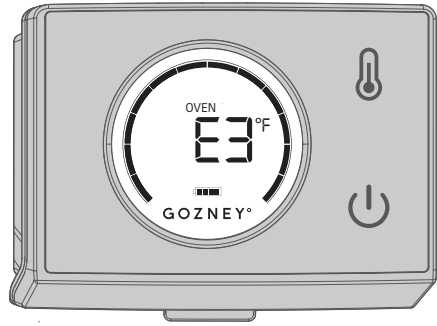
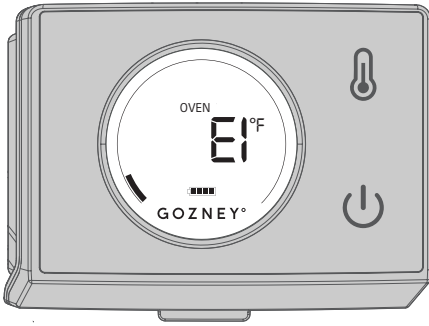

E1 ERROR CODE

If the thermometer is displaying an error code E1. This is caused by either:

- 1) A loose connection where the jack plug connects to the thermometer. Please ensure the jack plug is pushed fully in to the socket on the back of the thermometer.
- 2) Damage to the probe. The probe may need replacing. Please refer to maintenance instructions at the end of the manual.

E3 ERROR CODE

If the thermometer is displaying an error code E3. This is caused by the oven probe exceeding temperatures of 700°C/ 1292°F. Running the oven above this temperature may damage the unit.

To resolve this turn the gas burner off and let the oven cool naturally.

Do not try to rapidly cool the oven. This may crack the stone floor or cause stress damage to the oven.

Optional Accessories

Not included and must be purchased separately.

ROPE SEALED DOOR

The Rope Sealed Door will help you create the perfect cooking environment for baking, smoking or slow roasting over long periods.

With its adjustable vents you'll be able to control the temperature in the oven.

For more details visit the Gozney website.
www.gozney.com.

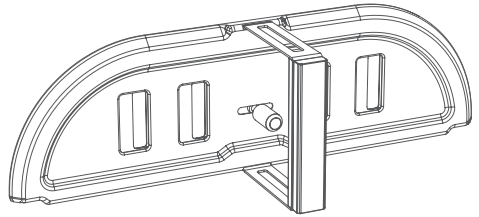

WARNING

Never use the door when the gas burner is lit. Always make sure the gas flame is extinguished and the gas dial is in the off position before installing the door.

FLUE EXTENSION

The Flue Extension will improve the efficiency of your oven and help reduce soot build-up around the mouth arch and within the oven.

For more details visit the Gozney website.
www.gozney.com.

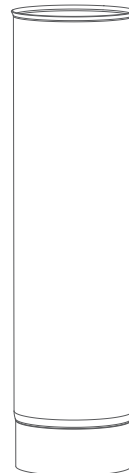

DOVE S1 MANTLE

Whether you're cooking Neapolitan pizza, roasting vegetables or smoking meat, the Dome S1 Mantle makes moving food in or out of the oven simple.

Easily bolting onto the oven, the Mantle is made from ceramic coated, food grade aluminum alloy for extra heat and scratch resistance.

For more details visit the Gozney website. www.gozney.com.

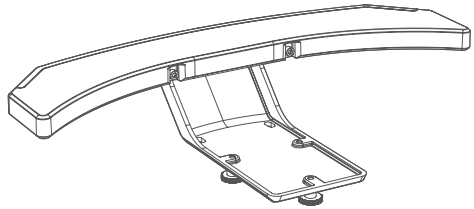

NEAPOLITAN ARCH

Master your leopard spotted crusts and take your pizza to the next level with this ceramic coated Neapolitan Arch. The Arch lowers the door height to enhance heat retention, creating the perfect environment for high-hydration doughs.

Includes Flue Extension.

For more details visit the Gozney website. www.gozney.com.

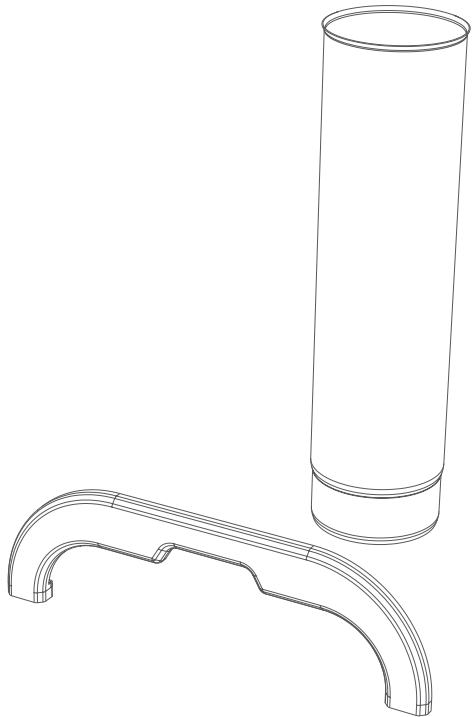

Your guide to burning gas.

3

Firing Up Gas

Connecting to Gas

Check that the gas you are using is specified on the data plate page.

The gas cylinder used must have a safety collar to protect the valve assembly. Do not use a cylinder that is rusty, dented or has a damaged valve.

We recommend using a 9kg gas bottle as a minimum in conjunction with Dome S1.

Connect the regulator to the gas canister, following the instructions for your regulator accordingly. Do not force the regulator as this could damage the gas bottle.

WARNING: If at any point you smell gas: Shut off the gas from the cylinder, turn off the switch on Dome S1 and extinguish any open flames.

If odour continues, move away from the Dome S1 and gas supply then contact your gas supplier or fire service.

Ensure that the LPG cylinder or regulator valve is closed.

Do not store a spare LPG cylinder under or near this appliance.

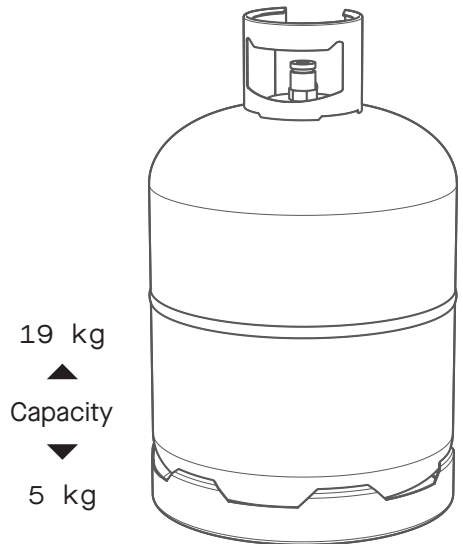

Gas Safety

Prior to use, check the oven, burner and venturi for blockages (e.g. food residue or insect nests - Wasps, Bees or Ants.) If an insect nest is found they can be dangerous and must be cleaned out thoroughly. Please refer to the cleaning and maintenance section for guidance.

Should the appliance extinguish for any reason, turn off the control knob and the cylinder gas valve. Wait 5 minutes before attempting to relight the appliance.

Some foods produce flammable fats and juices. Therefore the Dome S1 oven should be attended at all times whilst being used. Damage caused by fat and grease fires is not covered by warranty. If a grease or fat fire should occur, immediately turn off burner knob and the gas cylinder valve until the fire is out. Remove all food from the appliance.

A leak test must be carried out prior to using the appliance for the first time and whenever the gas cylinder is refilled or whenever the gas hose and regulator have been disconnected from the gas cylinder or appliance.

Remove all packaging before attempting to light the gas burner.

Please take a moment to review all of the safety requirements before operating the appliance when using gas.

⚠ Remove the cap from the gas inlet before connecting the hose. Make sure it is free of damage and debris.

⚠ Do not disconnect any gas fittings while the appliance is operating.

⚠ Check all gas hose lines and connections for cuts, cracks and other damage before each use. If there is excessive abrasion or wear it just be replaced with a Gozney approved hose assembly before use.

⚠ Gas cylinders must not be stored in enclosed areas.

⚠ Keep the fuel supply hose away from heated surfaces or direct sunlight.

⚠ Do not use any additional flammable substance whilst operating with gas.

⚠ Do not touch! The Dome S1 can get extremely hot when in operation. Be sure to wear protective gloves when operating the oven. Young children should be kept away.



Keep the cylinder outdoors in its upright position.



Do not connect multiple gas canisters to Dome S1 or store a spare within the same vicinity.



A regulator which complies with EN16129 or EN12864 must fit between the gas canister and the oven.



Do not position the gas canister under the oven.



Never use a naked flame to check for gas leaks.



Maximum length of hose cannot exceed 1.5m. In Finland, hose length cannot exceed 1.2m.



National requirements state how often to replace the hose. Please review this for your area.



Never fill the cylinder beyond 80 percent full.



Make sure the flexible tube is not twisting when the appliance is in operation.

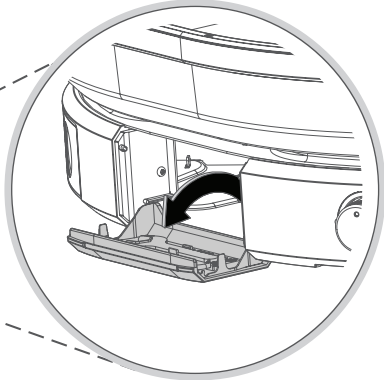
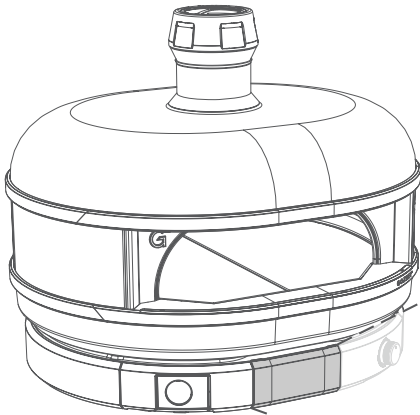

INSTALLING THE IGNITER BATTERY

Before using the gas burner for the first time you'll need to install an AAA battery into the ignition module. To do this open the front hatch, the module will be inside and to the left. The module is held in place by a magnet, detach the module and pull it to the front hatch before unscrewing the cap and placing the battery in (negative end first). Return the module to its original position, close the front hatch and you're ready to connect the gas bottle to the oven.

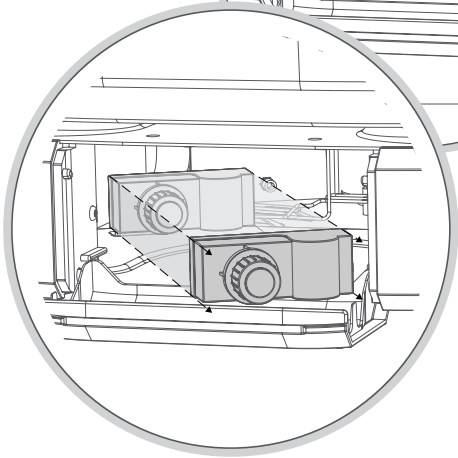
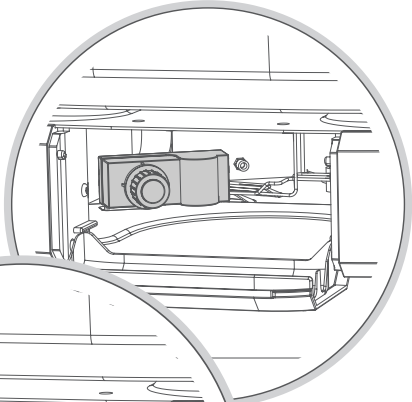

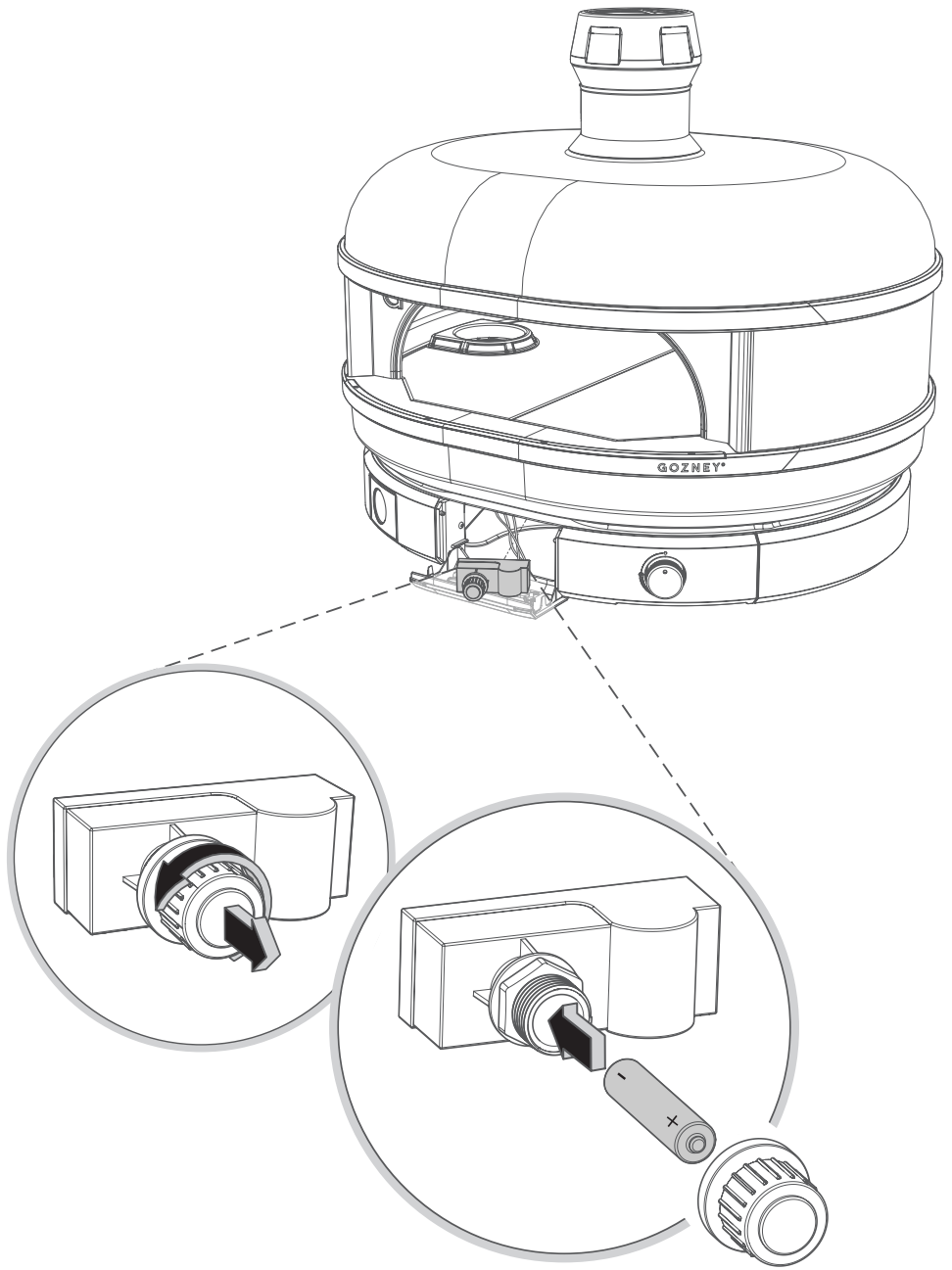

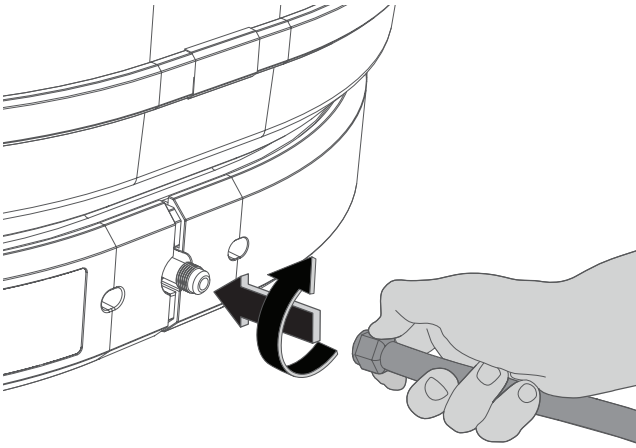

CONNECTING THE GAS HOSE

To attach the gas hose to your Dome S1 take the end of the hose and begin screw it onto the gas connector at the back of the oven. Use the spanner found in the front hatch to tighten. This connection must be tested for leaks before using the oven.

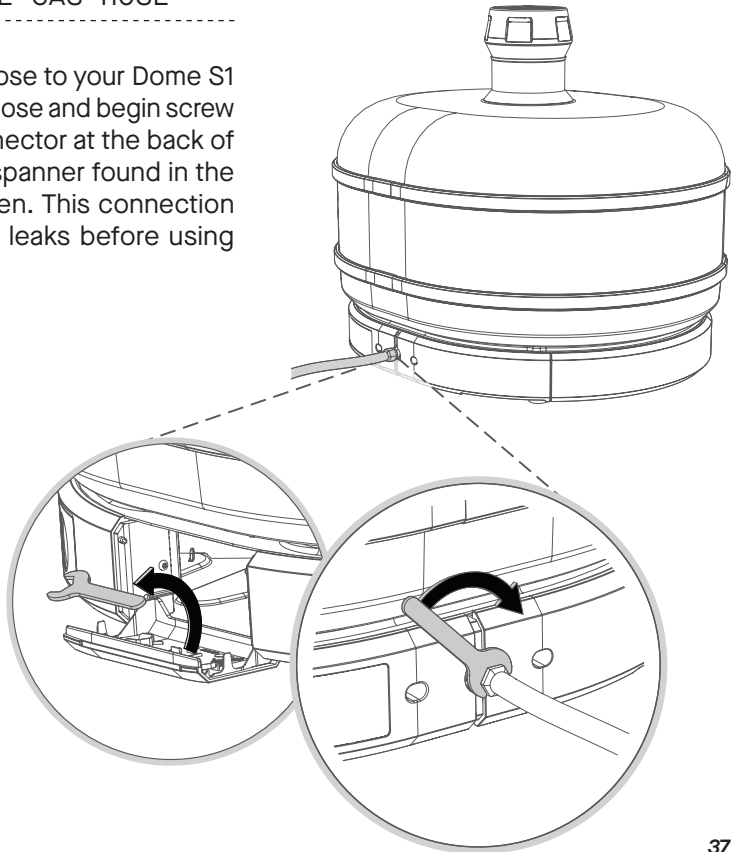

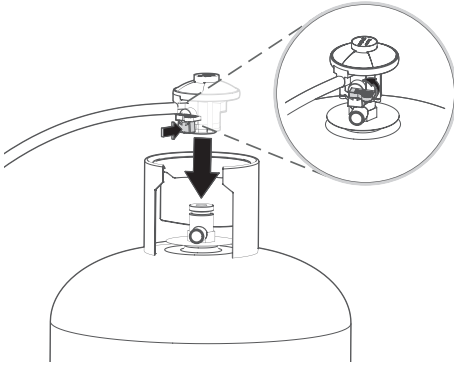

PUSH FIT REGULATOR

Make sure the lever is in the horizontal position so the button can be pressed. Pressing in the button, place the regulator onto the gas bottle. After releasing the button, turn the lever to a vertical position. This connection must be tested for leaks before using the oven.

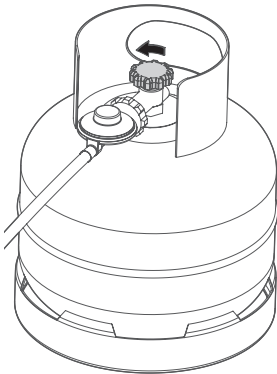
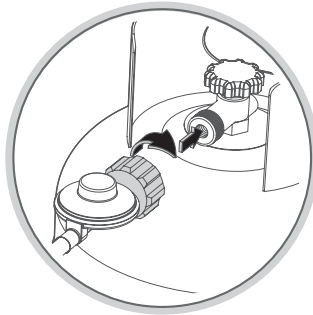
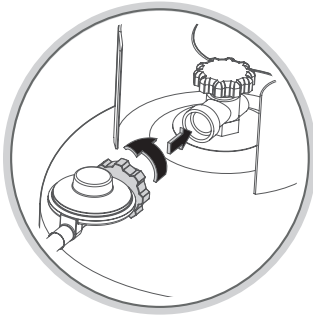

CLOCKWISE / ANTICLOCKWISE REGULATOR

Ensure the gas bottle is turned off. Align the regulator and the gas bottle threads and carefully begin to tighten ensuring the threads aren't crossed. Continue to tighten until a tight fit has been made. This connection must be tested for leaks before using the oven.

Testing For Leaks

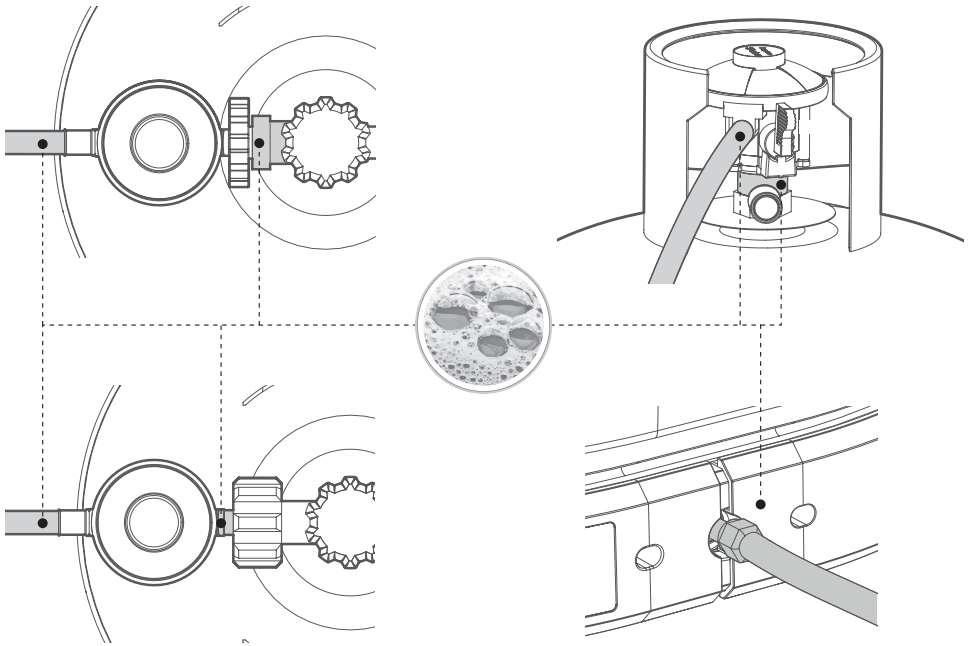

WARNING

You should always check for gas leaks every time you disconnect and reconnect a gas fitting. Never ignite burners when leak checking.

To test for gas leaks, apply a mixture of soapy water with a brush to the highlighted areas and any cracks along the hose. If a leak is present the solution will bubble.

If there is a leak at the hose to oven connection, re-tighten the fitting with a spanner and check for leaks by applying a soap-and-water solution to the highlighted areas with a brush. If a leak persists turn off the gas and **DO NOT OPERATE THE OVEN.**

If there is a leak at the valve connection, remove LPG cylinder. Do not operate oven. Use a different LPG cylinder and recheck for leaks with the soap-and-water solution.

Ignition

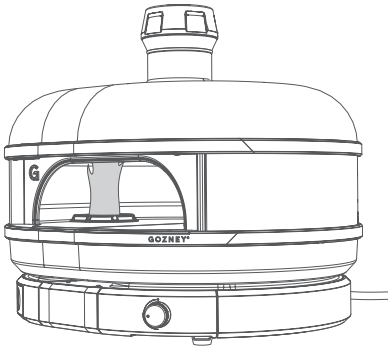
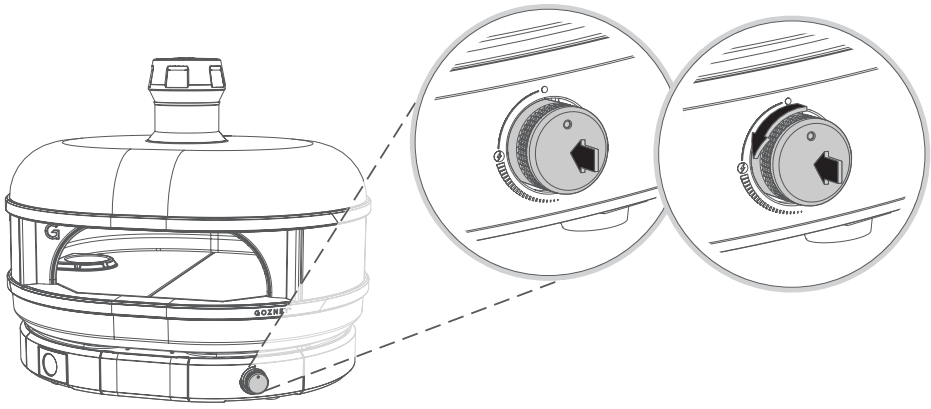

Remove the door and the stone retention wedges before lighting the oven. Do not use the door with gas burner. To light the gas burner press the control knob in and turn the knob 90° until you hear a clicking sound and the burner ignites.

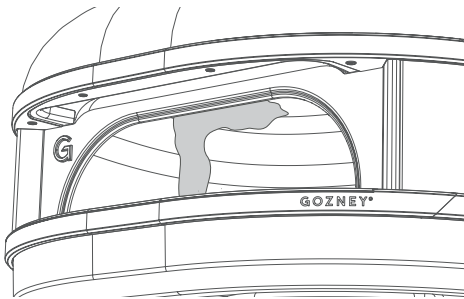

The flame should be yellow in colour and roll along the top of the oven.

First Firing

On your first firing we highly recommend to put the burner on a medium to low flame for 30 minutes to help cure the oven before moving to a high flame.

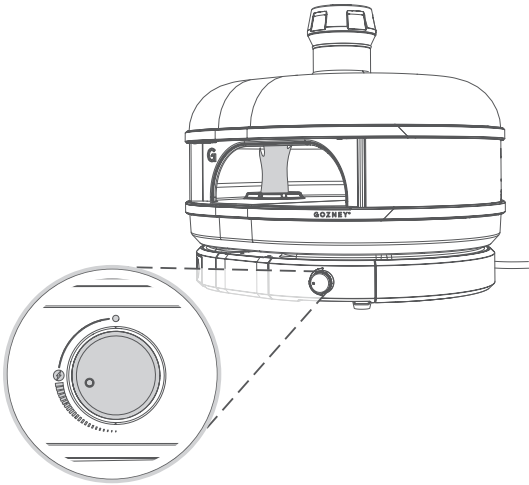
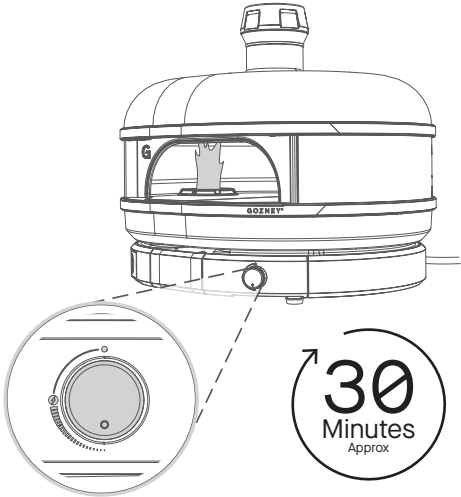

On subsequent firings after curing, you can bring the oven up to the desired temperature from ignition. If the oven has been dormant for an extended period, you should cure the oven again as if it was a first firing.

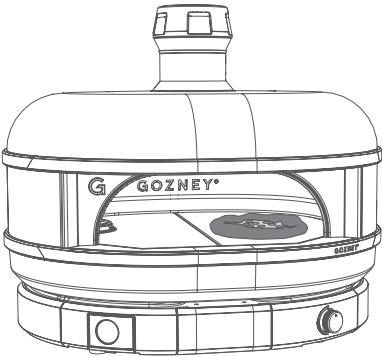

Troubleshooting Gas Burner

Problem Observed	Possible Reasons	Solution
Flame looks too small	<ul style="list-style-type: none"> Gas cylinder is near empty Gas cylinder is too small Ambient temperature is below 0°C Blocked burner 	<ul style="list-style-type: none"> Try replacing the gas cylinder if it is empty. The cannister maybe too small. We recommend a 9kg canister as a minimum. If the ambient temperature is below 0°C it is to be expected that a loss of power from the gas canister will occur. The burner could be blocked, please refer to cleaning instructions available in this manual.
Failure to ignite	<ul style="list-style-type: none"> Ignition battery is empty Blocked burner Gas canister is empty 	<ul style="list-style-type: none"> If firing for the first time or replacing a gas bottle the burner can take up to 30 seconds for the gas to flow through the system. Keep the control knob on until the pilot light has ignited. If the control knob is not making a clicking sound when pushed in try replacing the battery at the back of the unit. Review the maintenance section within the manual for help and guidance on this.
Noisy Flame	<ul style="list-style-type: none"> Incorrect ignition Blocked Burner 	<ul style="list-style-type: none"> If the burner is making a loud grumbling sound first turn the burner down to low flame and then back to high. If the sound continues turn the burner off for 5 minutes and retry igniting it. If the problem persists still review the cleaning and maintenance instructions to remove debris in the burner.

If the problem persists after trying the following solutions please contact Gozney for further support.

Disconnecting Gas

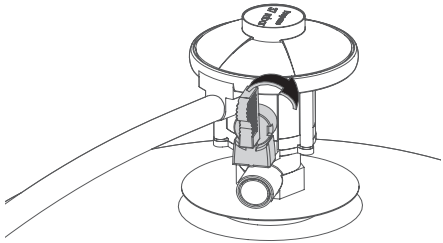

PUSH FIT REGULATOR

After cooking, be sure to turn off the gas from the gas canister first before turning of the Dome S1. This will allow any gas left in the burner or pipe to be used up safely. Three minutes after turning the gas off it will be safe to remove the regulator and turn the control dial back to the off position.

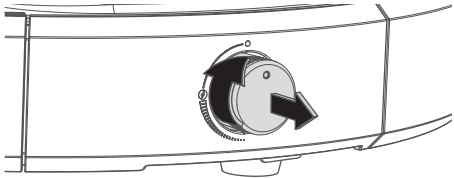
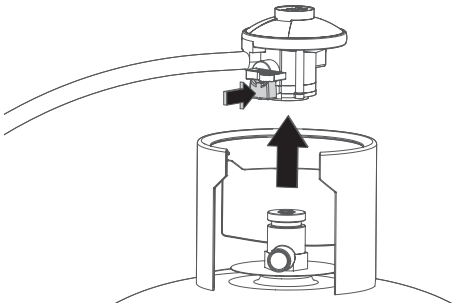

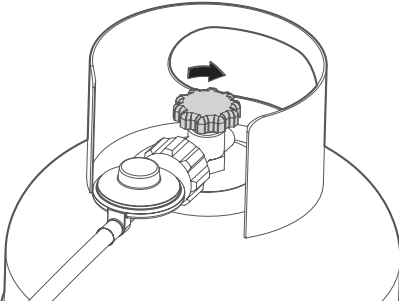

CLOCKWISE / ANTICLOCKWISE REGULATOR

After cooking, be sure to turn off the gas from the gas canister first before turning of the Dome S1. This will allow any gas left in the burner or pipe to be used up safely. Three minutes after turning the gas off it will be safe to remove the regulator and turn the control dial back to the off position.

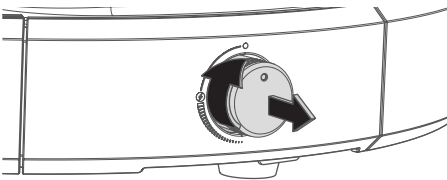
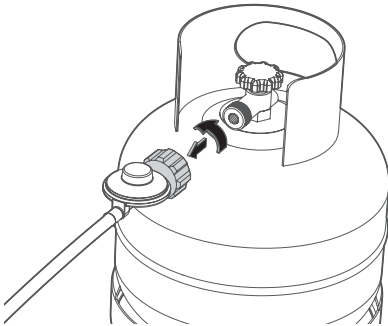

Your guide to general maintenance.

4

General Maintenance

Maintenance

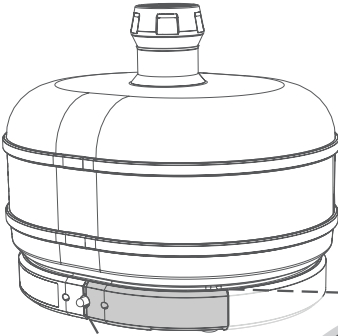

CLEANING THE VENTURI

If your burner's flame is overly yellow or making more noise than usual you may have debris blocking the venturi. When the oven is turned off, disconnected from the gas and cool, remove the rear right hand side panel using the torx screwdriver located in the front hatch of the dock. Use a vacuum cleaner with a long plastic nose to remove any debris. It's good practice to check the inside of the dock for debris regularly.

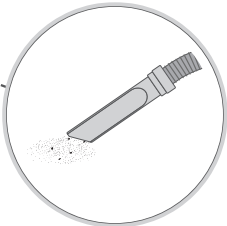
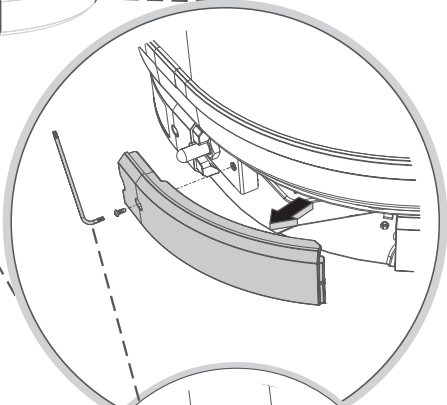

Cleaning The Oven

INTERNAL

The best way to clean the inside of the Dome S1 is to burn off any food debris or soot that is left behind. When the oven is over 343°C it will start self cleaning and any burnt on food will burn off after a period of four hours.

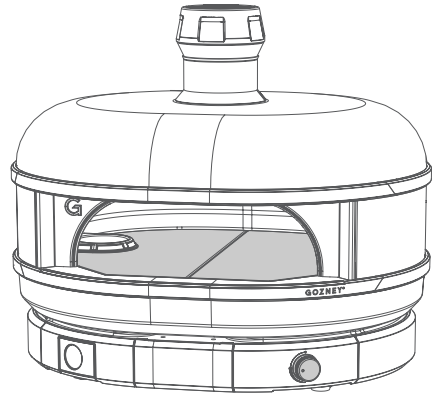

If there is any soot or debris left, wait for the oven to cool down and use a soft brush to dislodge, being careful not to apply too much pressure and damage the oven. Use a vacuum cleaner with a plastic attachment to remove the loose debris from the oven.

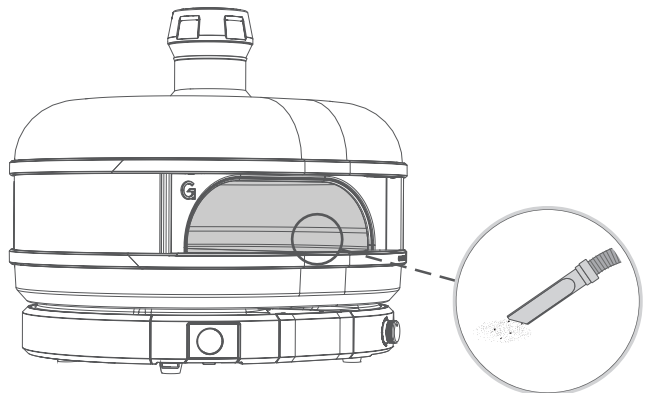

EXTERNAL

For the exterior of the oven use a non caustic bleach free cleaning spray on the dirty areas. Clean the area with warm soapy water and a sponge or non abrasive dish cloth and then wipe clean with paper towels.

Avoid spraying directly onto the thermometer or control dial.

Do not use abrasive cleaning products.

When the oven isn't in use store in a low humidity environment, to protect the unit from environmental damage. If you are placing a cover directly on Dome S1, ensure it's completely cooled down before covering.

When using the oven after a long spell of no use, we recommend firing the oven as if it is a first firing.

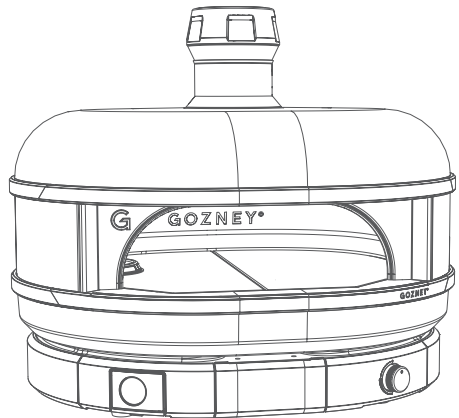
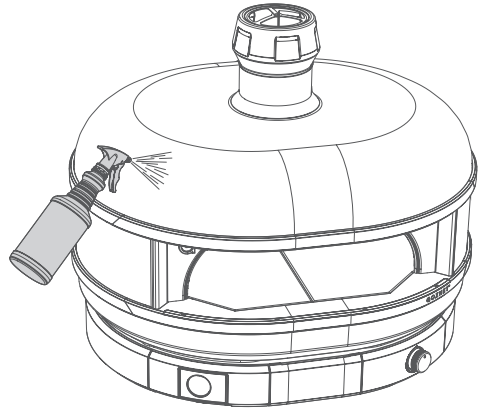

Replacing The Probe

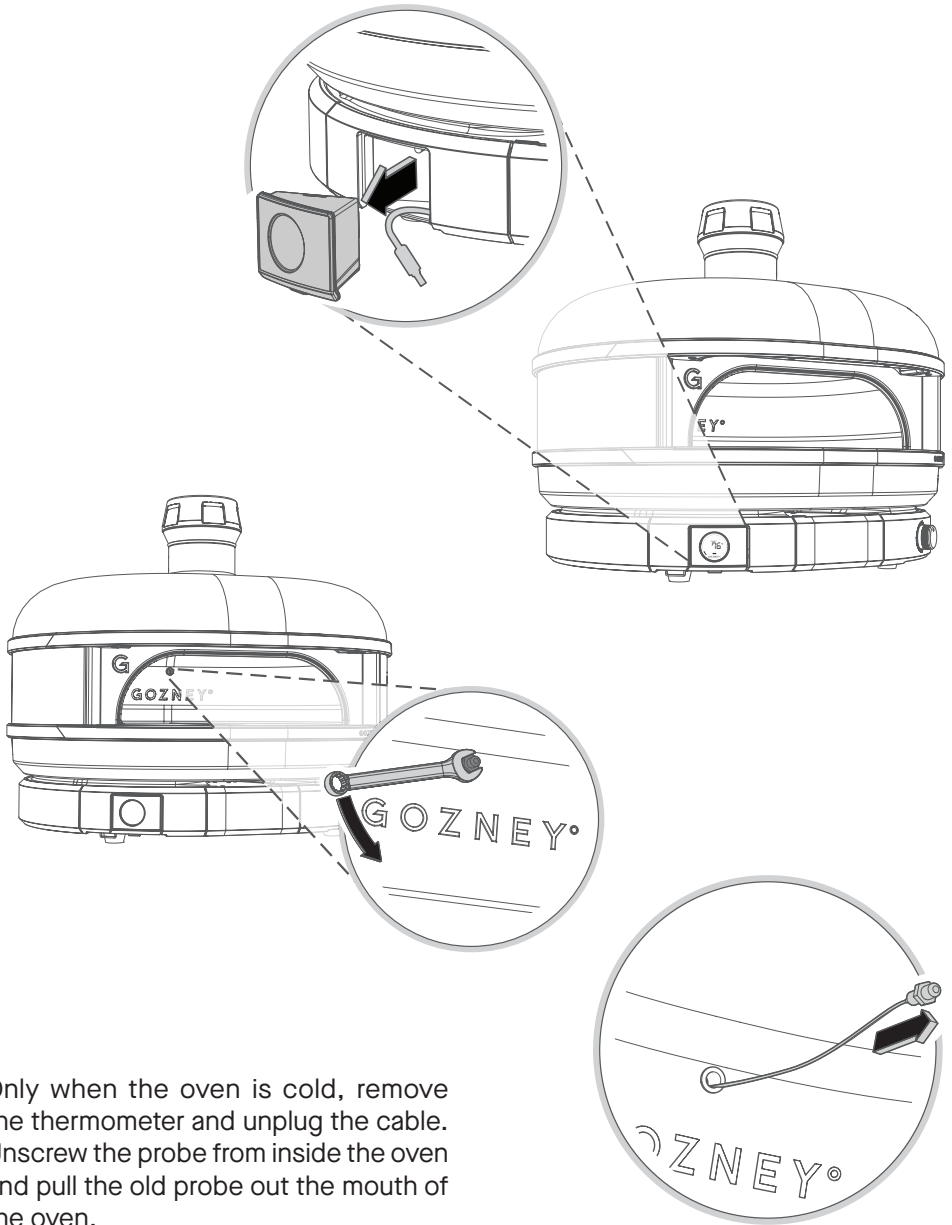

Only when the oven is cold, remove the thermometer and unplug the cable. Unscrew the probe from inside the oven and pull the old probe out the mouth of the oven.

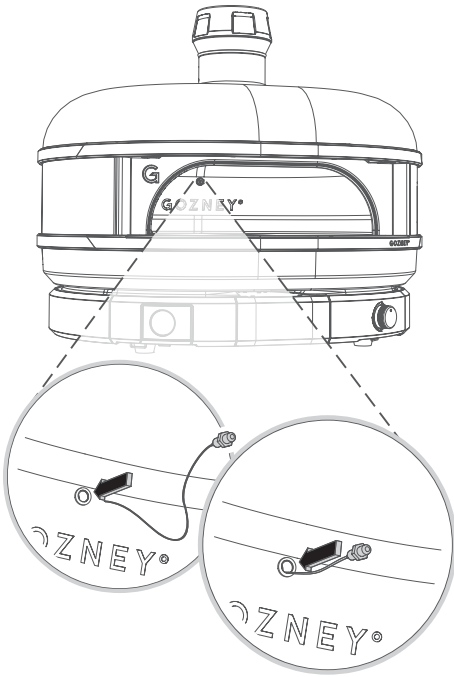

Push the new probe's wires into the hole and feed them through until they are visible from inside the area where the thermometer is normally housed. Hand tighten the probe in place, avoid using a spanner as you may damage the probe.



BEWARE:
Don't over tighten probe.



Plug the new cable into the back of the thermometer and return it to its position within the Dome S1 Dock.

Double check the probe is functioning by checking the digital temperature display and return the panel to the back of the oven.

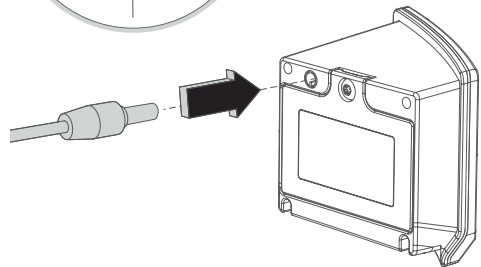
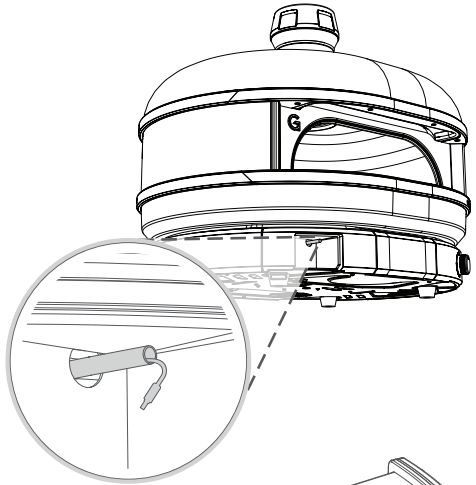

GOZNEY°