



Fusion 150 RW

MyFlame

CONTROL SYSTEM



Set Up & User Guide

APP SET UP

1 Available on the App Store
GET IT ON Google Play

2 Search for mus flame

3 Mus Flame app page with OPEN button

4 Mus Flame app icon

5 Log In / Sign Up screen

6 Register screen with email field and Get Verification Code button

7 Enter Verification Code screen with a numeric keypad

8 Add Device screen with a plus icon and Add Device button

9 Add Manually / Auto Scan screen with device selection icons A, B, and C

10 Select 2.4 GHz Wi-Fi Network and enter password screen with a Next button

11 Diagram of the device back panel with labels: WIFI, STAND-BY, FLAME, HEATER, and a button with a Wi-Fi symbol.

12 Reset the device first screen with instructions: Power on the device. Press the WIFI button 3 seconds until the indicator blink. Includes a diagram of the device and a Next button.

APP SET UP

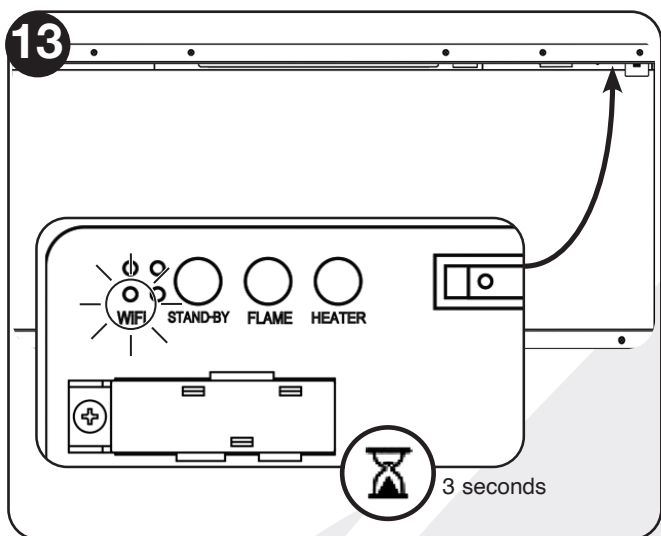

EZ MODE

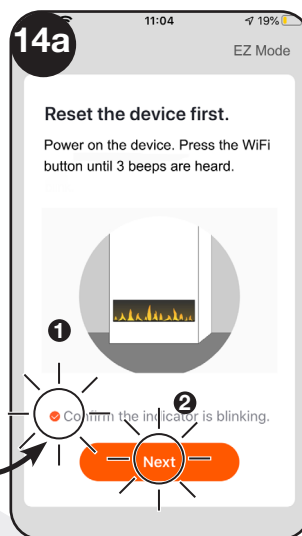

AP MODE

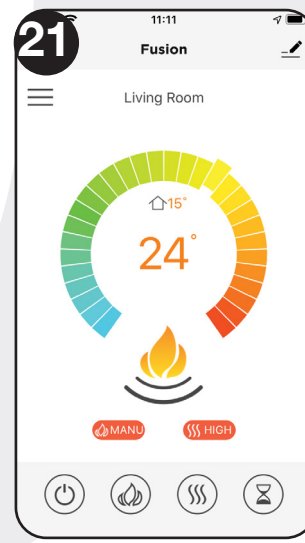
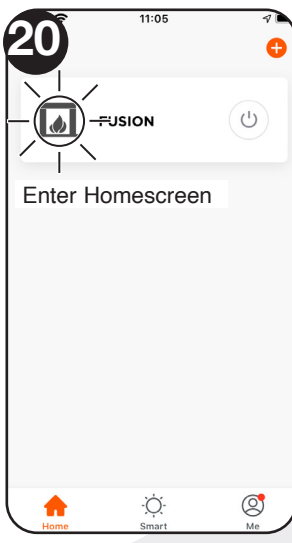
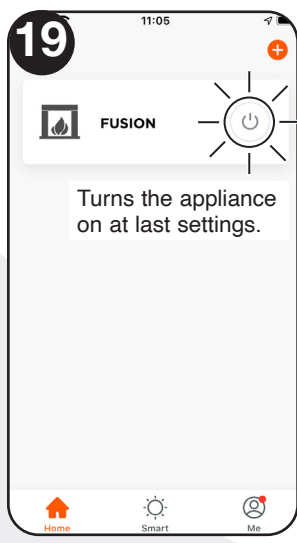
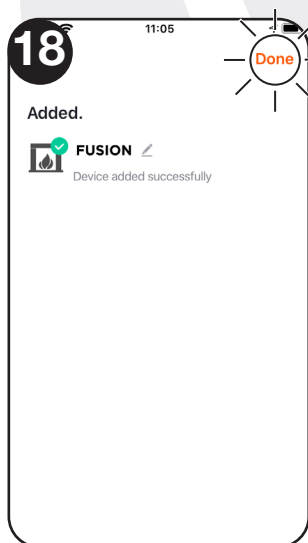
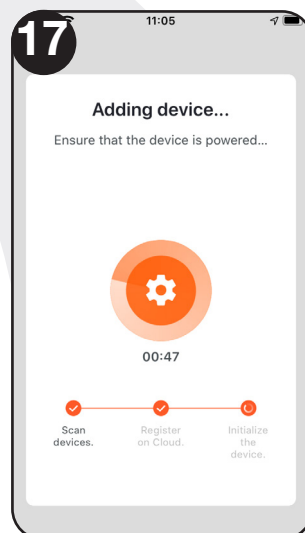
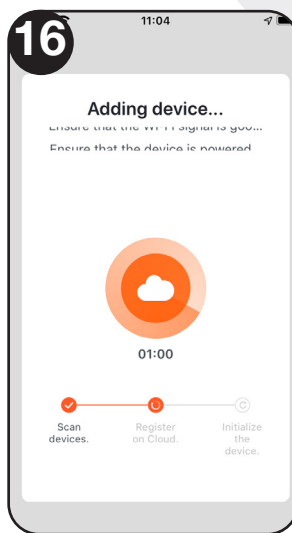
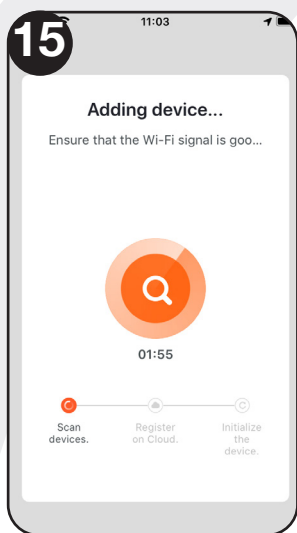
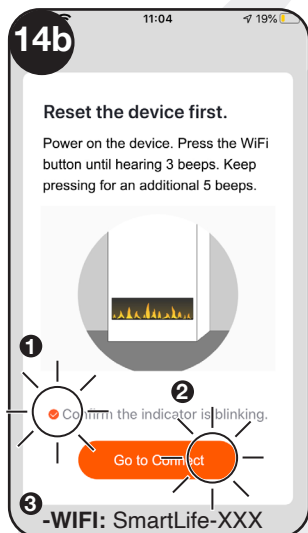

MANUAL OR AUTOMATIC CONTROLS

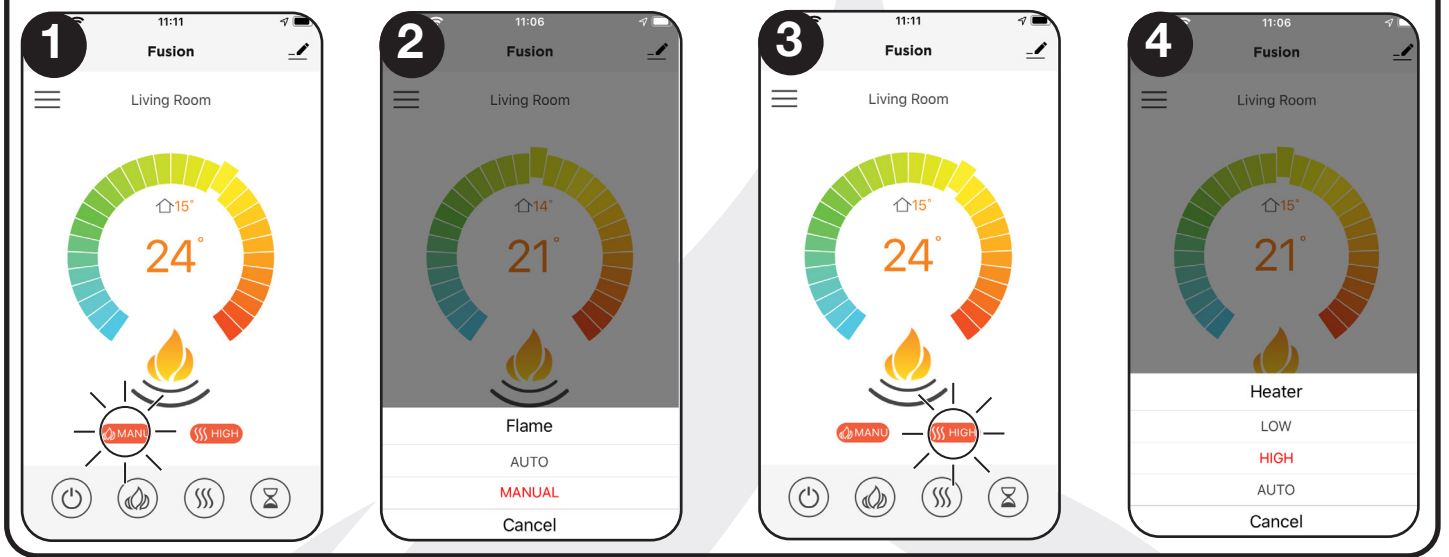

FLAME ADJUSTMENT - MY FLAME



FLAME ADJUSTMENT - FLAME

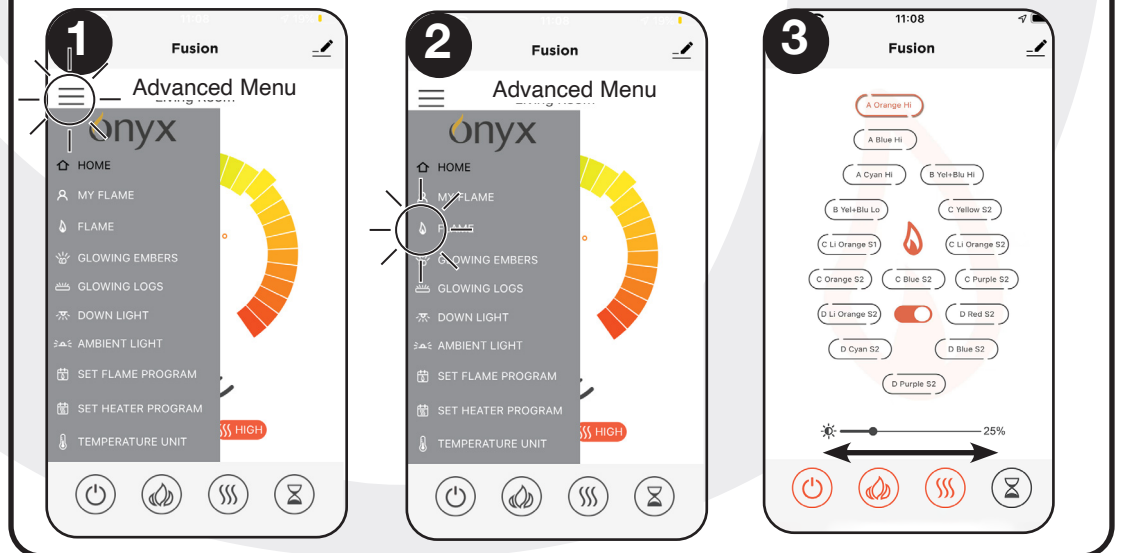

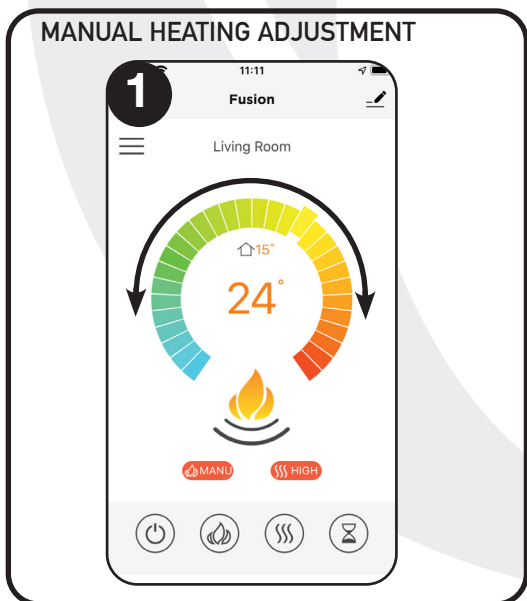
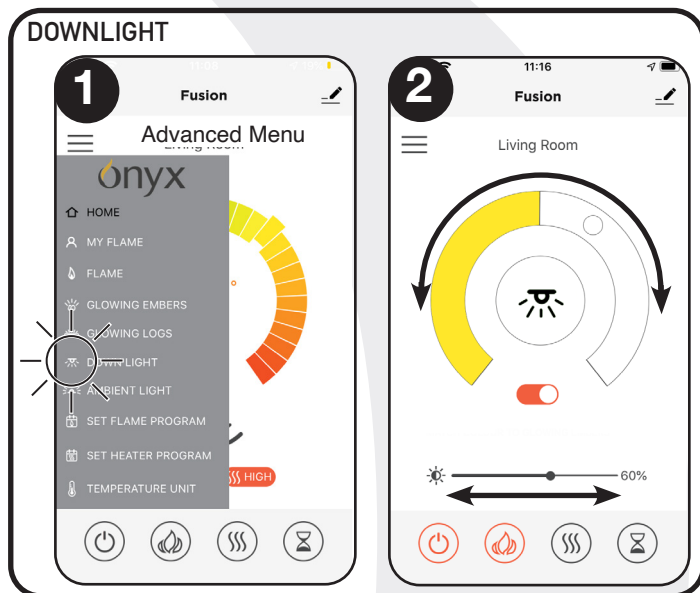
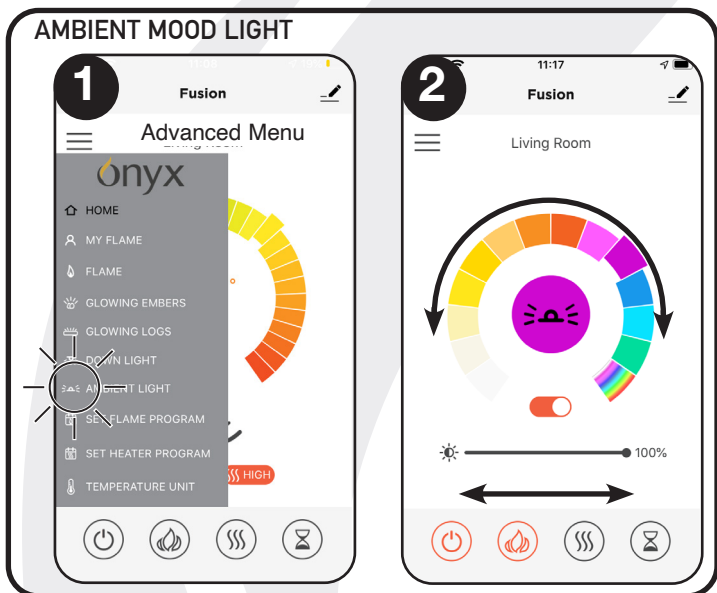
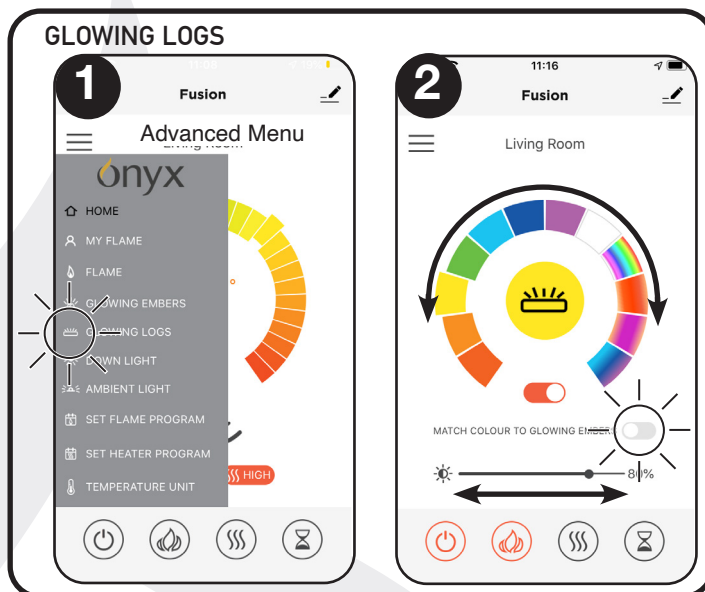
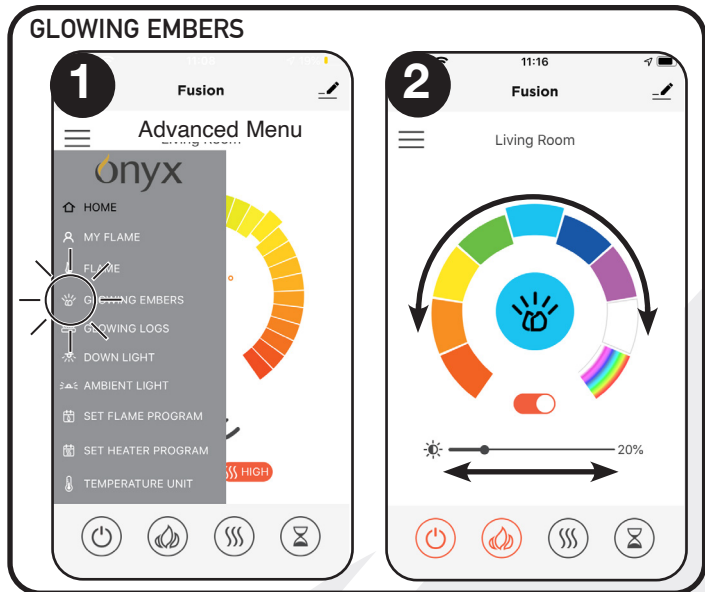

PRE-SET ADJUSTMENT - MY FLAME

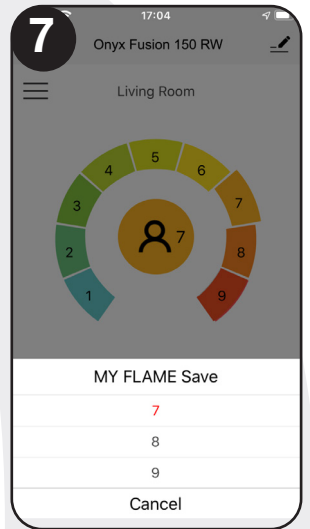
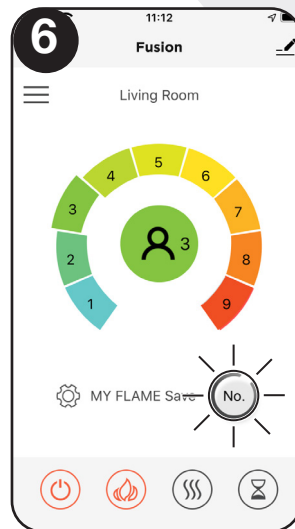
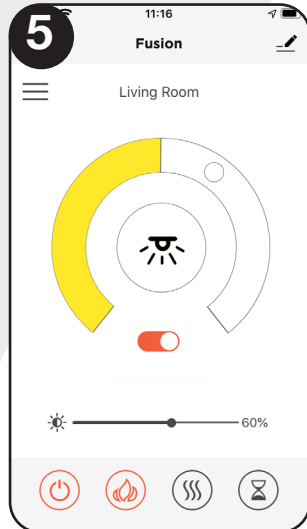
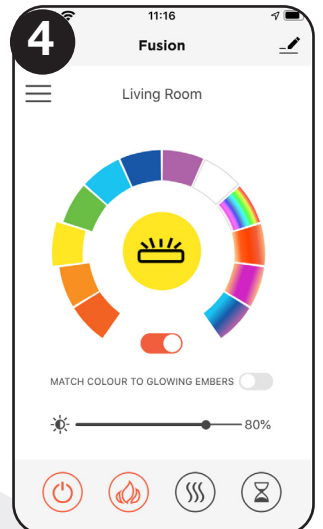
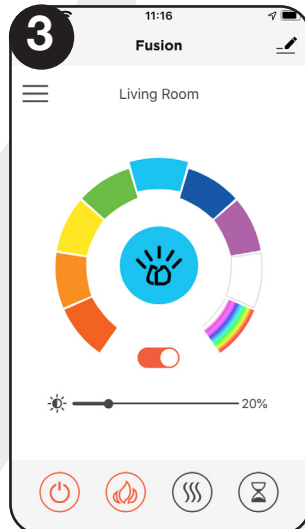
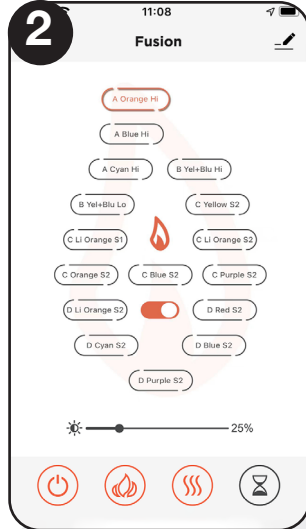
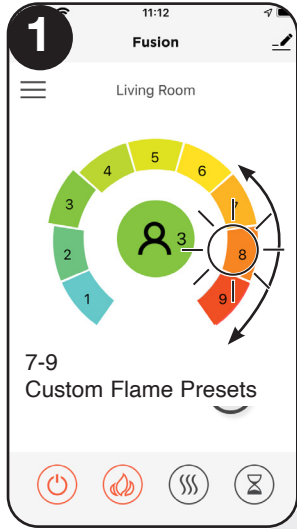

SET FLAME PROGRAM

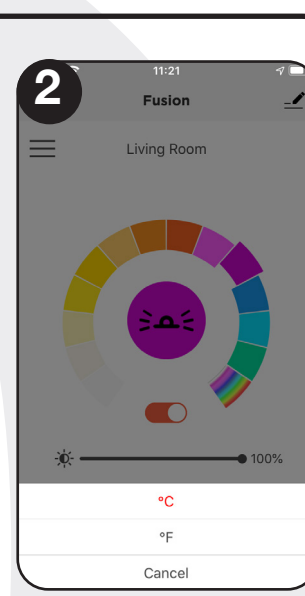
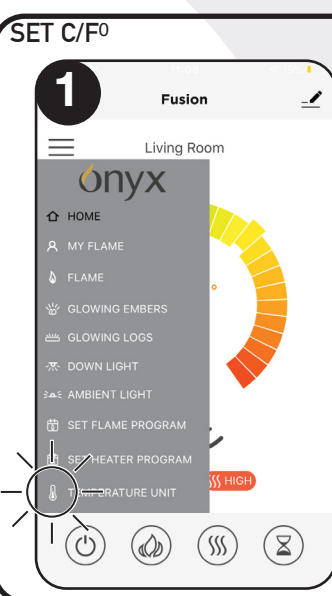
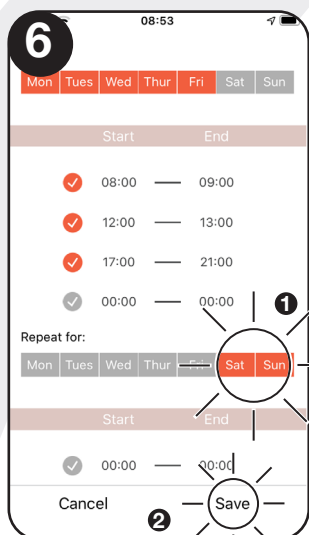
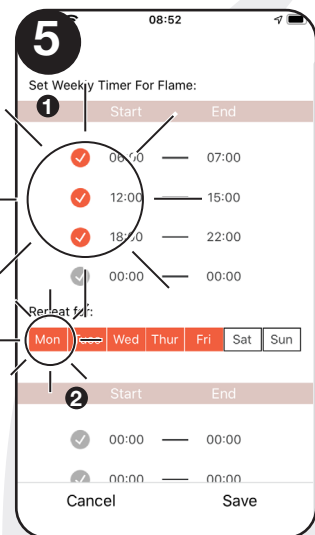
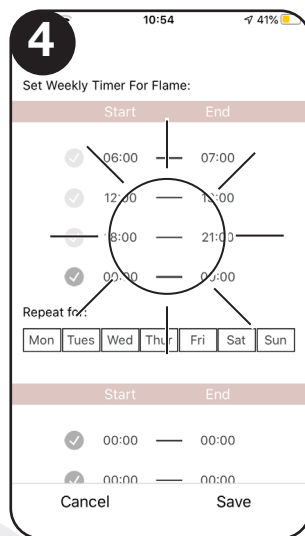
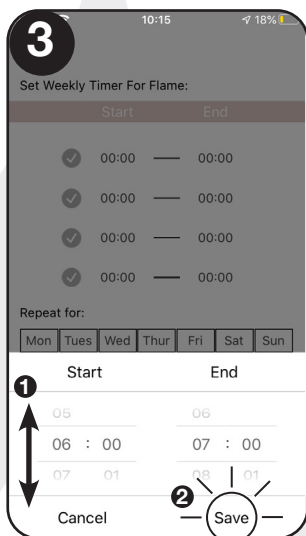
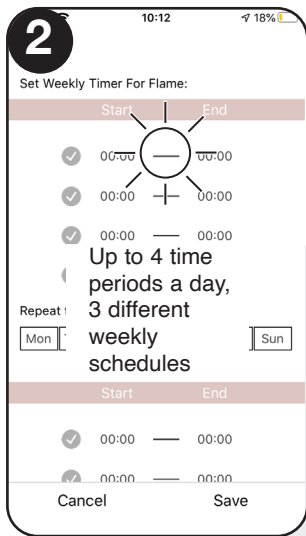

TIMER

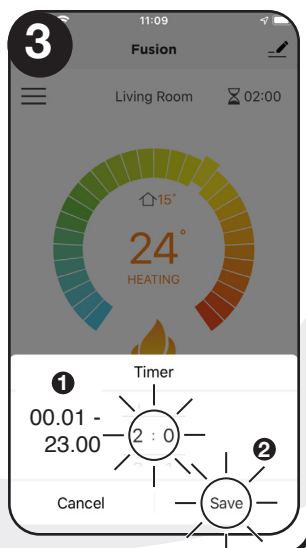
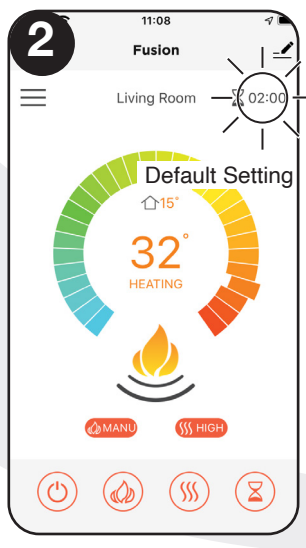
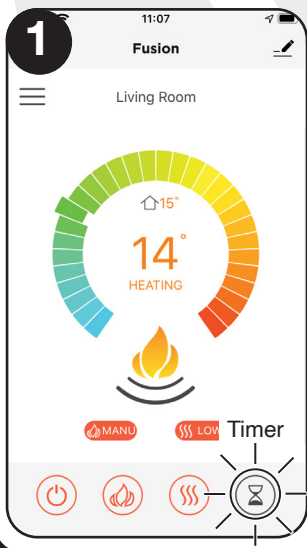

SET HEATER PROGRAM

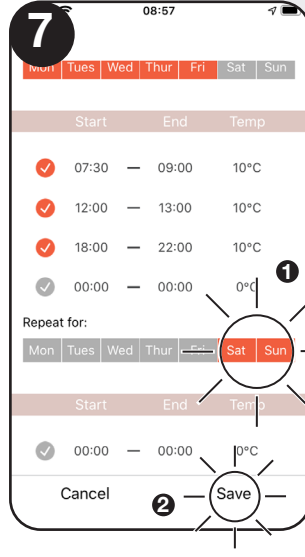
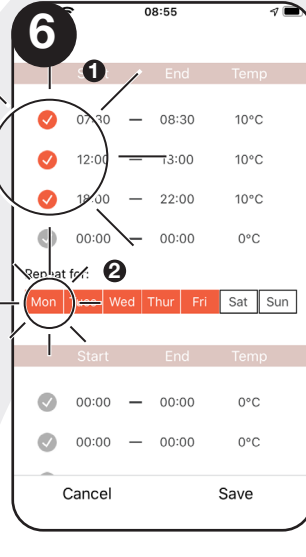
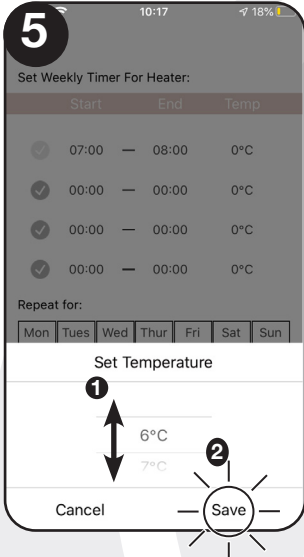
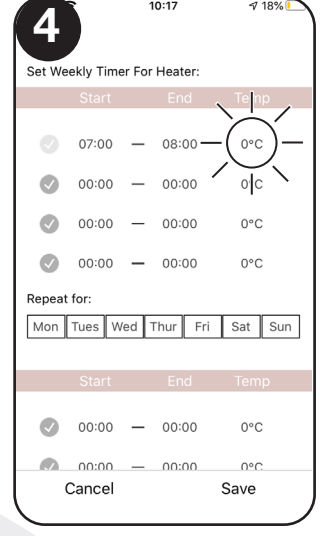
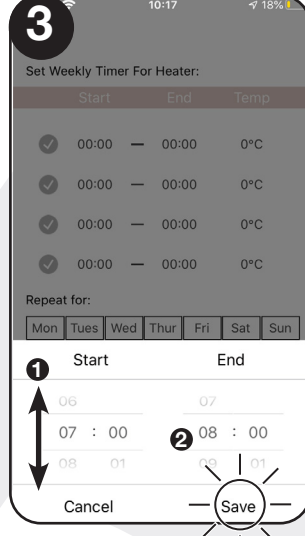
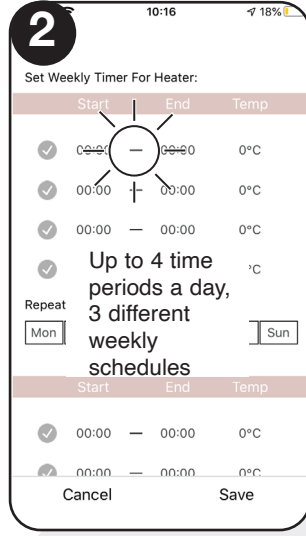

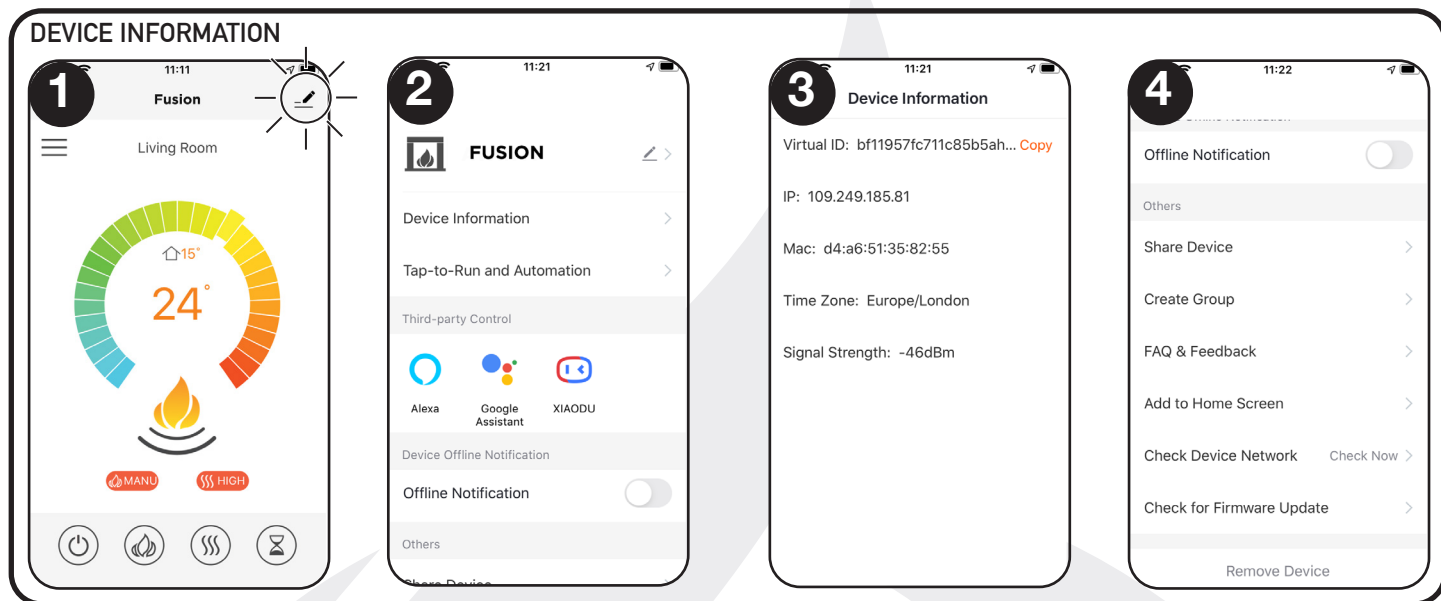

onyx

WIFI

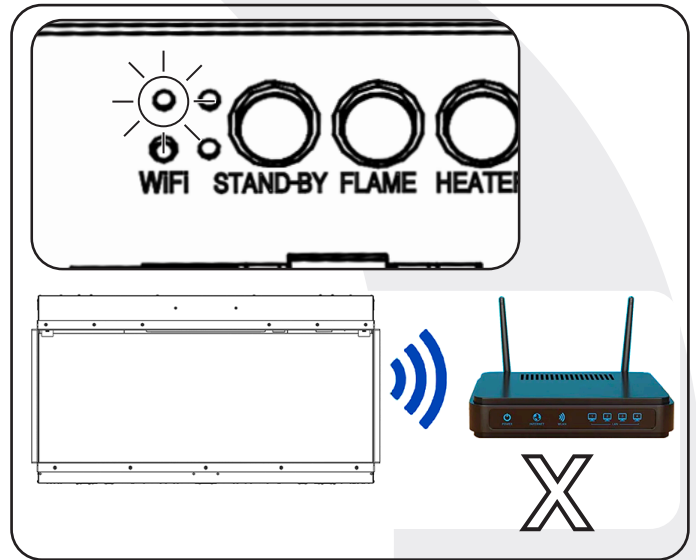
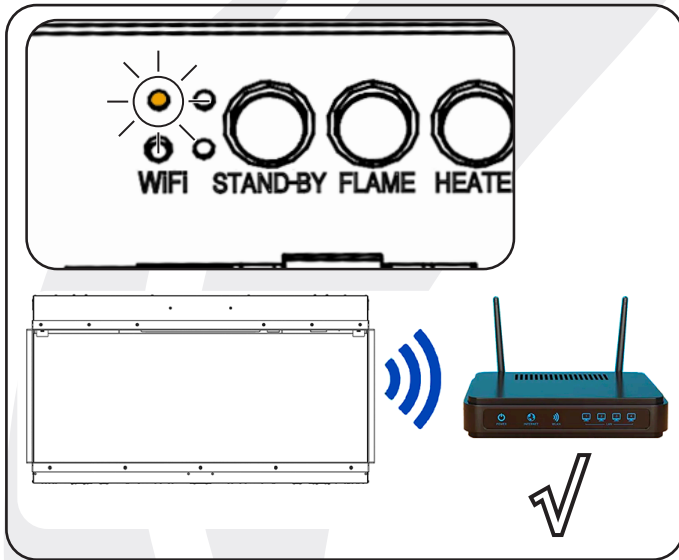
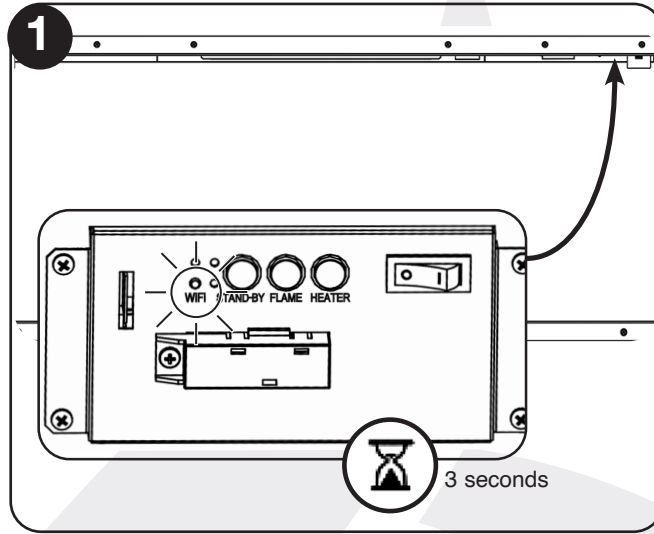



FOR ENQUIRIES IN THE U.K (EXCLUDING NI):

Gazco Ltd, Spitfire Avenue, Skypark, Clyst Honiton, Exeter, Devon, England EX5 2FR

Tel: (01392) 261900 E-mail: info@onyxfires.com

FOR ENQUIRIES IN EUROPE (INCLUDING NI):

Stovax Heating Group (NI) Ltd (Comp reg NI675194), 40 Linenhall Street, Belfast, BT2 8BA

DX 400 NR Belfast Tel: +44 (0)1392 261990 E-mail: northernireland@onyxfires.com

onyx



PR3267